



## VePAL CX350S

### Advanced All-In-One Installer Meter

#### CATV Network Testing Simplified

VeEX® VePAL CX350S is a portable, all-in-one test solution for legacy analog and digital Cable TV networks, supporting SLM, DOCSIS, Ethernet, and T1 test capabilities.

#### Platform Highlights

- Robust, lightweight chassis packed with powerful features for demanding environments and test conditions
- High resolution color 7" touch-screen with graphical user interface
- Ethernet LAN management port for remote control, back office applications, and workforce management
- Fast and efficient test result transfer to USB memory stick or FTP upload via LAN or DOCSIS ports
- Maintain instrument software, manage test setups and channel tables, process measurement results and generate customer test reports using included ReVeal™ PC software
- Extend field testing time using interchangeable Lilon battery pack/s
- Ability to lock user interface to prevent unwanted human interference during long-term testing
- WiFi Wiz with InSSiDer SSID Analysis\*
- WiFi Spectrum Analyzer\*
- VoIP and IPTV\*

#### Key Features

- Frequency range from 5 MHz to 1 GHz
- Comprehensive SLM measurements (single channel, system scan, tilt, and installation check)
- Video and Audio power level measurements (Annex A, B, C signals)
- Forward and Return path QAM measurements (MER, Pre/Post BER, Constellation diagram, Histogram, and Equalizer on/off mode)
- Advanced Digital measurements\* (HUM, EVM, Phase Jitter, Symbol Rate Error, Frequency Response, Group Delay)
- Dual band DOCSIS 3.0 certified Cable Modem with 8x4 Channel Bonding\*
- Spectrum view to capture impulse noise and interference
- Home Installation Procedure (HIP) with user defined test limits
- Built-in Upstream Generator\* (CW, QPSK, QAM 16/64/128/256 modulation)
- Single 10/100/1000-T/X Ethernet port (BERT, Throughput, RFC2544 and Loopback testing)\*
- Built-in TDR\* supports up to 2 km / 6000 ft of standard coaxial cable
- Single DS1 Transmitter/Receiver with Balanced (100Ω) interfaces\* for full Rate DS1 and Fractional N x 64 kbps or N x 56 kbps testing
- ISDN PRI call setup\*

\*Optional features

## SLM Features

### Single Channel Measurement

Analog and digital carriers are very different in terms of signal content and power distribution and thus require the advanced SLM techniques supported in the CX350S.

In **analog** mode, video and audio levels, V/A, Gated C/N, Adjacent channels and HUM are measured.

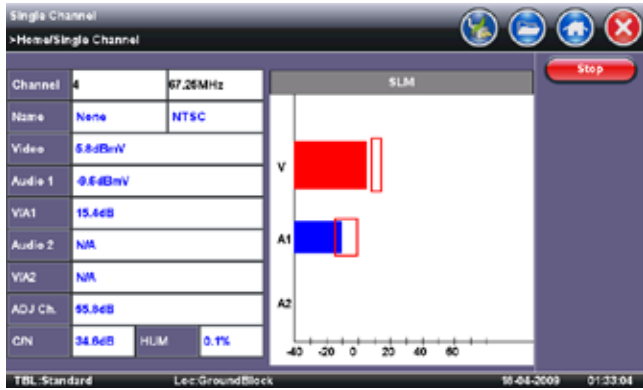

In **digital** mode, average power, MER, Pre-BER, Post-BER, Error seconds, and constellation diagram are displayed. User programmable location thresholds and test point compensation are useful utilities enabling fast, simple and automated testing of carrier signals.



### Advanced Digital Channel Analysis

Digital pictures do not show signal impairment until it is too late because the margin between acceptable quality and failure is quite small.

**Constellation diagrams** – A valuable tool to help detect the presence of noise, phase jitter, interference, gain compression, laser clipping and ingress, all of which impact overall signal quality and thus reduces Modulation Error Ratio (MER). The Advanced Digital Analysis option has added in depth analysis of a QAM carrier with Phase Jitter, Group Delay, Symbol rate error, Frequency error, Maximum Amplitude Change, HUM, C/I, C/N, and Frequency response measurements.

**Adaptive Equalization** – The built-in equalizer does a great job of improving MER of a QAM signal, but it is also important for technicians to know how hard the system is working to ensure adequate margin for system degradation. The adaptive equalizer in the CX350S can be turned off to make troubleshooting marginal amplifiers, ingress, CPD and related impairments easier.

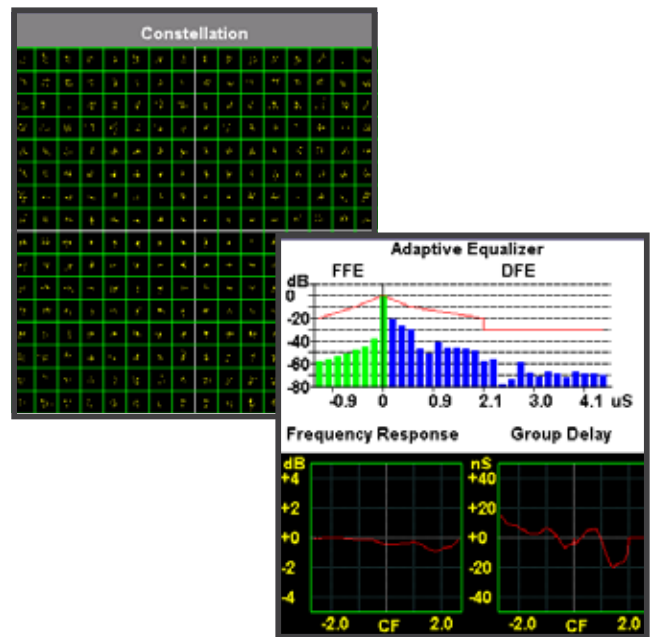

### System Scan

Within seconds, all analog and digital channels at a service location are measured. Signal parameters including channel number, channel name, frequency, modulation type and power levels are measured. Signal degradation or tilt can be easily pinpointed using on-screen markers and the zoom mode.

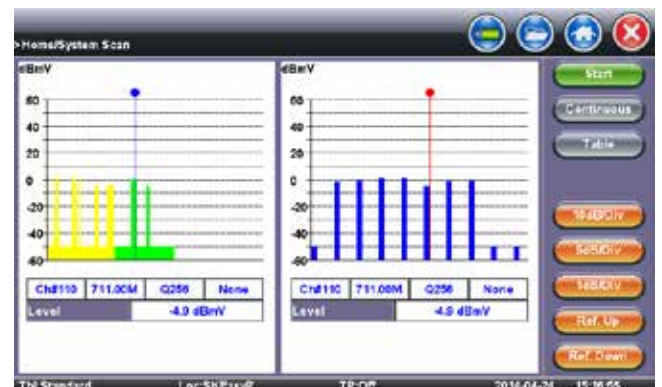

## SLM/TDR Features

### Histogram Analysis

Noise impulses can suddenly disrupt a digital carrier but it is difficult to detect without monitoring the carrier over a period time.

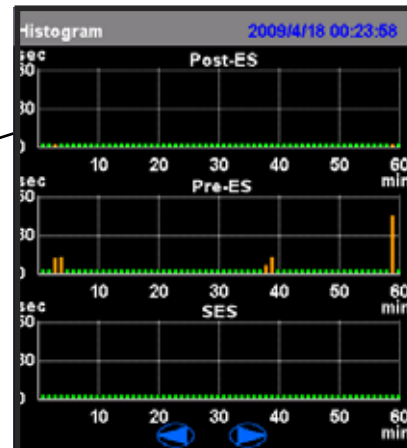

The histogram feature records level, MER, Pre-BER, Post-BER, and Error seconds on per second time bucket for up to 60 minutes. The results are shown in graphical format that allows easy correlation of measured parameters down to one-second resolution.

### Tilt

Tilt measurements identify distortion over the frequency range allowing technicians to apply correct equalization or compensation to the HFC network. Up to eight analog signals and digital carriers including DOCSIS channels can be predefined on a channel table and selected to perform the tilt measurement. The measurement can be performed between the lowest and highest channel or any user selectable channel by tapping the applicable bar on screen.

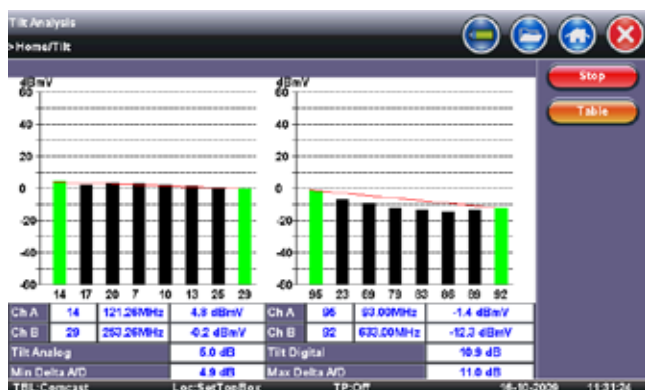

### Installation Check

Up to 16 analog and 16 digitals are checked against preset location thresholds. The feature is particularly useful to verify and turn up service at new installations or after service is restored. Pass and Fail conditions are color coded for easy interpretation and test results are clearly displayed. This automatic test procedure adds consistency to the final service qualification. The CX350S can store up to 20 channel tables each of which can be pre-programmed with channels to be used for installation check.

### Time Domain Reflectometer (TDR)

The optional TDR applies advanced signal processing techniques to detect opens, short circuits, splices, taps, water ingress and other elusive impedance mismatches on coaxial cables up to distances of 2 km (6,000 ft) with  $\pm 1\%$  accuracy.



The cable under test is scanned within seconds, allowing the user to view the full run and to identify faults quickly.

Novice TDR users will appreciate the pre-set gain and pulse width feature which automatically adjust the vertical position of the trace for each range setting. All major operating and setting parameters can be easily accessed using only 4 tabs located at the bottom of the screen.

Experienced technicians will benefit from selectable impedance settings and adjustable Velocity Propagation (VP) factors to perform various tests on different cables.

## Spectrum Analysis

Throughout a CATV system, power is distributed in the form of QAM, QPSK, TV and FM carriers, pilot tones, test signals, and noise. Impulse noise and narrowband ingress are detrimental because they distort or obliterate desired signals in the network.

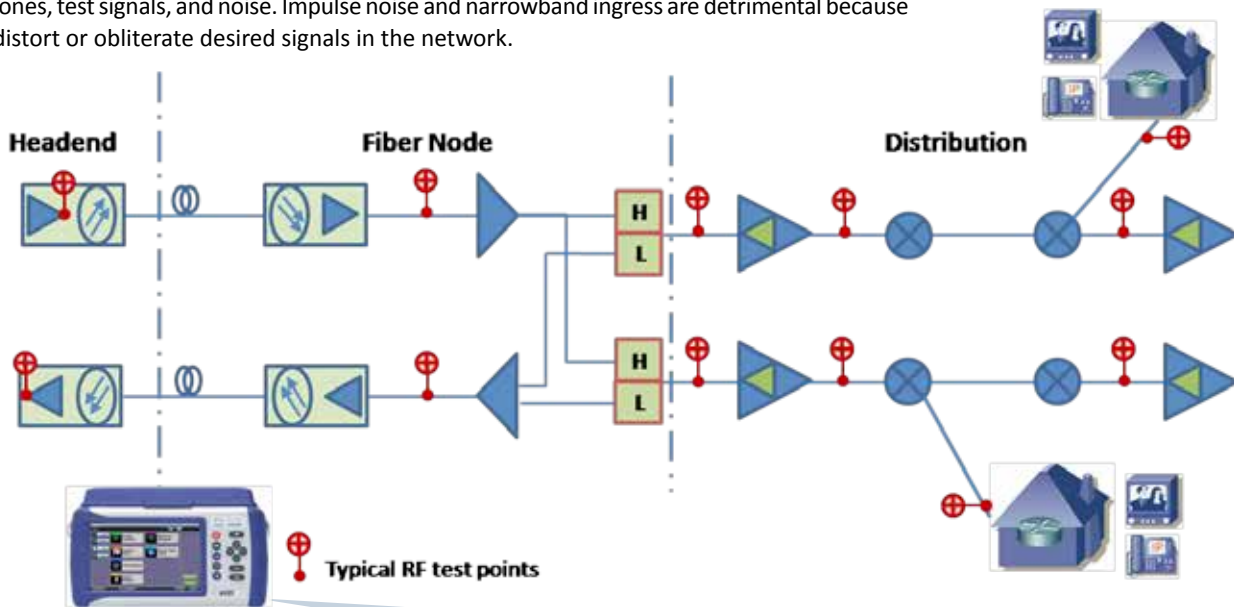

### DOCSIS Transmission

DOCSIS 2.0/3.0 standards include recommendations and limits for downstream and upstream RF performance. Forward Error Correction (FEC) and deep interleaving techniques help protect IP data against radio frequency (RF) noise impairments; however network performance is often impaired by interference. Cable modems transmitting on frequencies with high levels of noise are susceptible to packet loss and uncorrectable FEC errors are indicative of degraded upstream performance and poor data throughput.

### Upstream Ingress

The return path is more susceptible to RF impairments because the frequency spectrum is heavily used for Hum and Citizen Band radio transmissions. Interference is not only limited to RF transmissions; Impulse noise generated by electric motors, switches, lightning strikes, high voltage power lines, vehicle ignitions, or household electrical appliances at the subscriber premise are particularly damaging to data transmissions where short bursts of interference can seriously reduce data throughput.

The return path is also very vulnerable to a phenomenon known as Noise funneling. The summation of all unwanted noise (Gaussian, ingress and impulse noise) coming from both subscribers and the cable plant itself affects the return transmission system and needs to be monitored.

The CX350S is equipped with powerful spectrum analyzer features including a high dynamic range, markers, peak hold, variable resolution bandwidth (RBW) and variable dwell time (sweep speed) to help troubleshoot, identify and fix interference related problems.

### Laser Clipping

Ingress and impulse noise can cause signal clipping when upstream fiber amplifier inputs are presented with excessive power levels. As more carriers are added to the return path using channel bonding, composite power to the laser will increase.

### Common Path Intermodulation Distortion (CPID/CPIM)

Spurious signals appearing in the upstream composed of distortion products of the downstream signals. Lower frequency components are passed through the diplex filter and amplified by the return amplifier. Common Path Distortions are intermittent by nature and are directly related to poor connections, corrosion, kinks and radial cracks in the cable.

### Downstream Ingress

Interference originating outside the CATV system (co-channel and ingress) or generated within the system (inter-mod, hum and cross modulation) occur frequently in the forward path.

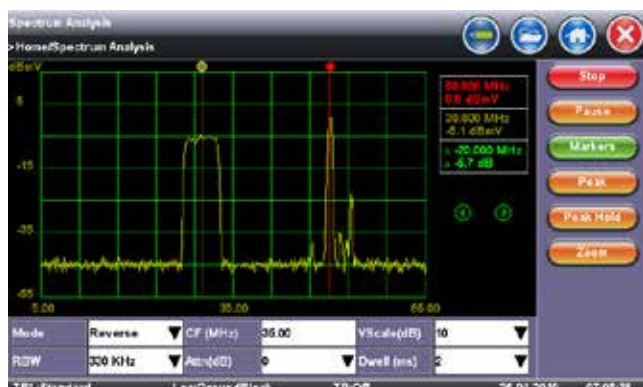

## DOCSIS® 3.0

### DOCSIS 3.0/Euro-DOCSIS 3.0 Modem Emulation

Equipped with a CableLabs® certified cable modem based on latest generation DOCSIS 3.0 technology, the CX350S enables technicians to perform dual band RF connection tests, without having to carry a separate test modem on service calls.



### Intuitive Results

At a glance, the technician is able to view a summary of the ranging and registration process, check AES and Baseline Privacy (BPI+) encryption status and identify which connection parameters have passed or failed.



### Link Statistics

The cable modem offers data transmission speeds up to 220 Mbps (downstream) and 100 Mbps (upstream) using four-channel bonding technology. A range of downstream and upstream link connection parameters including frequency, power, modulation, symbol rates and signal margins are evaluated and displayed.



### Verifying Upstream Channel Bonding

DOCSIS 3.0 provides several enhancements, most notably channel bonding giving cable operators a flexible way to increase bandwidth to customers. Upstream speeds in particular have come under a lot of pressure due to a sharp increase in user generated content such as video and photo uploads, driven by the proliferation of social and networking sites.

Checking RF Levels - Significant consideration must be given to the cumulative RF power loading that is realized with upstream channel bonding. Four upstream DOCSIS channels transmitting simultaneously can result in a large contiguous channel loading. To avoid excess power hitting the return path fiber-optic transmitter and to reduce the possibility of laser clipping, the power levels of each channel can be carefully monitored in the link measurement tab.



### IPv6 Support and Network Server Verification

Once successful upranging is complete, the DOCSIS 3.0 modem registers with the Cable Modem Termination System (CMTS) and checks for an IPv6 address before looking for an IPv4 address. IP addresses from the network servers (DHCP, TFTP, TOD, and DNS) are discovered and clearly displayed.



### VeTest Throughput

VeTest enables download and upload throughput testing to various customer specific servers.



## Upstream Signal Generator (USG)

Evaluate the bandwidth and noise performance characteristics of the reverse path with a choice of CW, QPSK, 16 QAM, 64 QAM and 128 QAM modulation types using industry standard symbol rates. Transmitting a known reference signal between 5-65 MHz (Annex A) or 5-42 MHz (Annex B) into the reverse path at a user defined power level and modulation, allows a technician to evaluate phase and amplitude distortions resulting from any misalignment present in the network. Injected reference signals can be used to determine the headroom in the reverse path and to identify laser clipping resulting from signal overload.

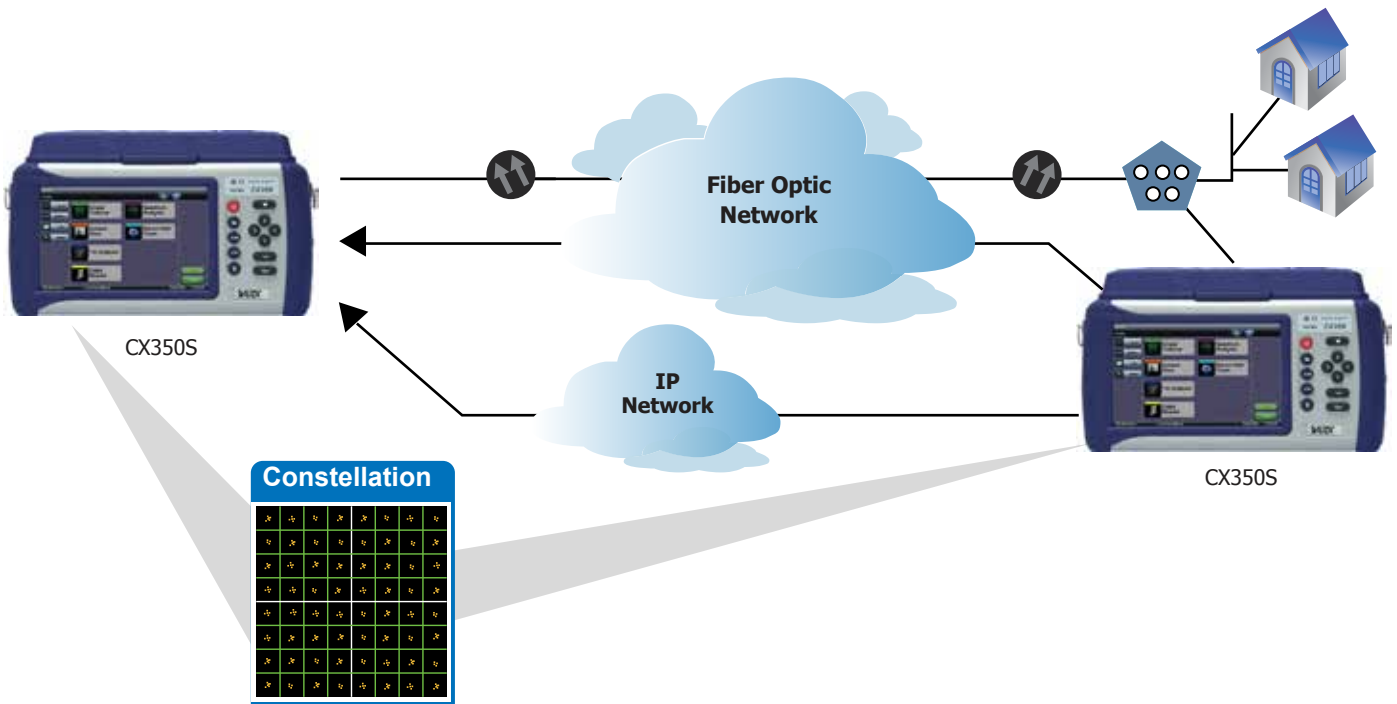

The USG function fitted with Forward Error Correction (FEC) capability, is compatible with the Return Path analysis options found on other VeEX products, including the CX180R RPM System, CX3XX Series and CX150-D3+ CATV test sets, as well as select 3rd party CATV QAM analyzers. Depending on the companion analyzer used, Digital channel power, MER (equalized and unequalized), Pre/Post FEC, EVM, Phase Jitter, Hum, Group Delay and Symbol rate errors can all be evaluated. These tests are invaluable to characterize the in-channel flatness, in-channel group delay, and adaptive equalizer operation.

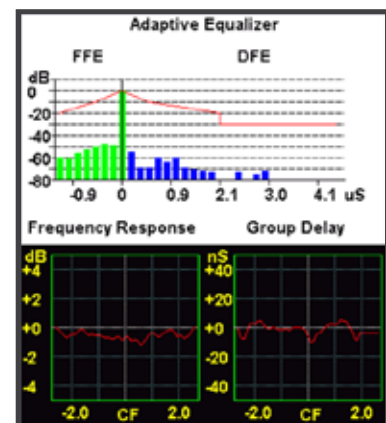

## Return Path Sweep

The CX350S incorporates a sweep transmitter (USG) capable of generating sweep tones over a 5 MHz to 65 MHz frequency range with 125 kHz resolution, and amplitude levels ranging from 0 to 58 dBmV with 1 dB resolution.

When paired with a companion CX380 Series handheld unit or a CX180R RPM System located in the Headend, the entire return path frequency spectrum can be precisely characterized for DOCSIS 3.0 communications. Protection “Guard Bands” can be pre-configured to prevent test tones interfering with active DOCSIS transmissions.

The sweep system communicates the user defined sweep tables and measured test data over the Internet, freeing up valuable downstream bandwidth typically used by conventional telemetry systems found in competitor systems.



## Remote View

Return path troubleshooting and testing is simplified when the CX350S is equipped with the Remote View option.

Utilizing a wired (10/100Base-T or DOCSIS) or wireless (3G UMTS or 802.11 WiFi) Internet connection, a technician operating the unit in the field is able to view real time measurements being performed by the companion CX380 or CX180R located in an upstream Node or Headend itself.

Developed specifically for dual ended test applications, evaluating MER, BER and Constellation and other advanced measurements like group delay and frequency response is extremely fast and convenient. In addition to sweep, real-time return path ingress measurements performed in the Headend by the CX380 or CX180R spectrum analyzer can also be viewed, thus making it a truly unique solution for upstream testing and characterization.

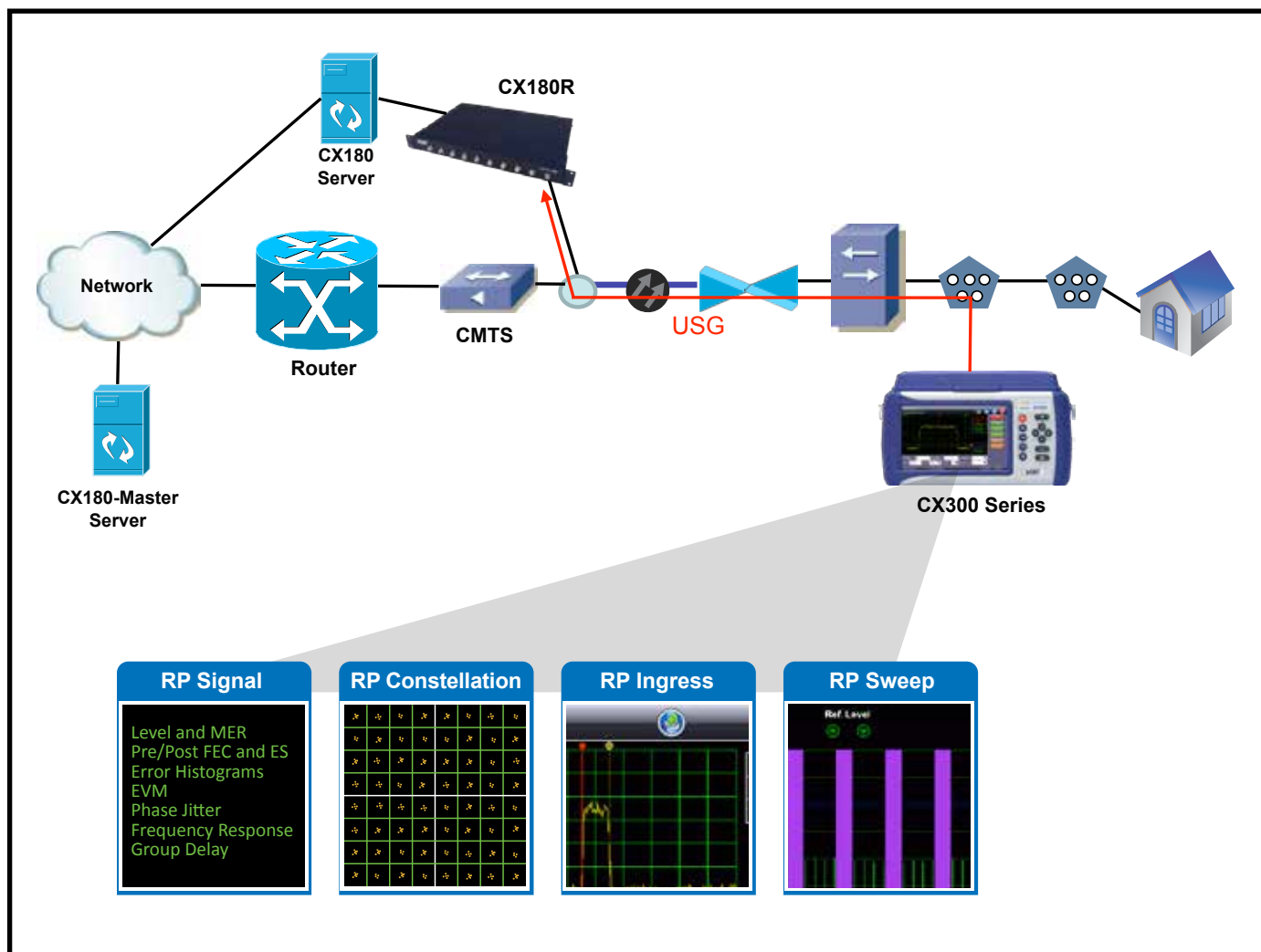
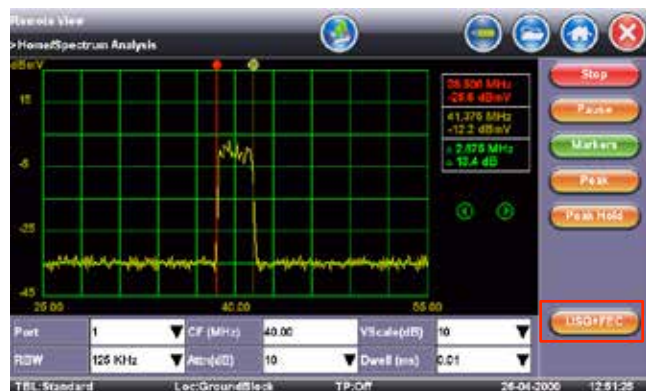

## Ethernet

### Test Interfaces

Single copper (RJ45) and optical test ports (SFP) support 100% wire speed traffic generation and reception for 10/100/1000Base-T, 1000Base-SX, 1000Base-LX or 1000Base-ZX full-duplex networks at all packet sizes.



### RFC2544 Compliance Testing

Automated test suite performs throughput, latency, frame loss, and back-to-back frame tests, and checks all industry recommended frame sizes (including two user defined frame sizes) up to full line rate. The test can be performed with a far end test partner in loopback mode (symmetrical traffic) or peer-to-peer mode (asymmetrical traffic). User defined test thresholds ensure accurate SLA assurance/verification while an advanced SLA mode generates background streams to closely approximate actual live traffic conditions.



### Intelligent Loopbacks

Four modes are available for looping test traffic:

- Layer 1 - incoming traffic is looped back unaltered
- Layer 2 - incoming unicast traffic is looped back with MAC source/destination addresses swapped
- Layer 3 – same as layer 2 with both MAC and IP addresses swapped
- Layer 4 – same as Layer 3, with UDP/TCP ports swapped

### BERT

Layer 1, 2, 3, and Layer 4 BER tests are supported. PRBS, stress or user defined test patterns simulate various conditions. Service disruption measurements including CRC error checking are performed. BER testing is possible using a physical loop at the far end (Layer 1), or using a second test unit or intelligent loopback device in Smart Loop or in Peer-to-Peer mode.

VLAN stacking (Q-in-Q) is supported for Metro and Carrier Ethernet applications. Up to three tags makes provision for carrier/service provider assigned VLANs, while retaining the VLAN of customer traffic.



### Throughput Testing

Testing with multiple streams enables service providers to simulate and qualify a variety of applications and perform Ethernet QoS measurements.

#### • Multiple Streams Generation

Up to eight individual traffic streams can be configured with independent VLAN stacking (802.1ad Q-in-Q), VLAN ID (802.1Q), VLAN Priority (802.1p), ToS and DSCP settings.

#### • Delay and Jitter Measurements

Frame delay (PDV) and inter frame delay variation (IPDV) measurements based on RFC3393 recommendations are performed on test traffic during BER or throughput tests when unit is equipped with the Jitter software option.





## Ethernet over DOCSIS

Today's cable operator network infrastructure, which combines a 40G/10G backbone with DOCSIS 3.0 over HFC, has strongly positioned MSOs to offer business class Ethernet based services to small and medium businesses. Key service offerings include guaranteed data, hosted voice, online backup and security, and other cloud based services.

Using its built-in Ethernet test traffic engine, the CX350S can generate traffic over the DOCSIS test port to verify bi-directional, end-to-end DOCSIS throughput rates with a far-end Ethernet test device. Verification is done from the Customer Premise to the Headend CMTS.

In Ethernet over DOCSIS mode, the CX350S emulates the Cable Modem and simulates the customer's Ethernet traffic, up to maximum DOCSIS 3.0 throughput rates. This unique capability is ideal for MSOs to verify their Metro and Carrier Ethernet Service offerings.

### True Gigabit Ethernet Throughput SLA

Actual Cable Modem CPE verification can be performed by connecting the CX350S' Ethernet test port to the Cable Modem's Ethernet port and generate test traffic to the far-end Ethernet test device connected behind the CMTS.

#### Benefits

- The Asymmetric RFC2544 test suite offers an automated verification of throughput rates.
- The Throughput application enables for deeper troubleshooting and verification with differentiation of traffic flow types (Constant, Ramp, and Burst) and different frame size configurations.

### Testing Premise

From the Customer Premise, test directly at the RF interface or through the real Cable Modem's Ethernet interface. At the CATV Headend office, connect a MPX100 or any other VeEX Ethernet test set behind the CMTS. Here the MPX functions as a Responder, with only an IP address needed to be configured on the test port. The CX350S functions as the Controller via the RF or Ethernet interface, running the RFC2544 Asymmetric test suite.

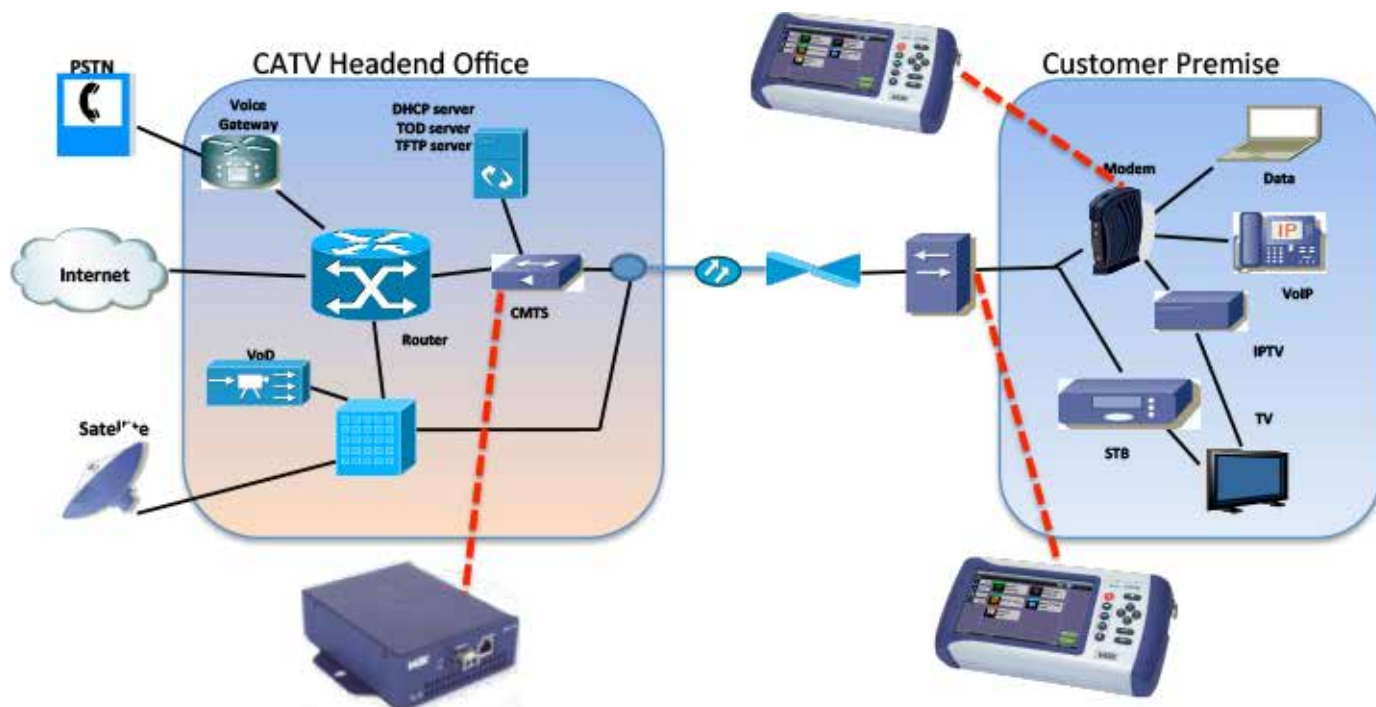

## T1 Testing

### Quick and Easy Setup

Encountering a variety of complex daily tasks is common in today's network environment, so technicians need a tester that is easy to configure and which doesn't require extensive product training beforehand. Taking this into account, the test interface, signal structure, and test pattern setup boxes are structured logically so the user can quickly and efficiently configure the unit via an intuitive graphical menu.



### DS1 Loopback

Loopbacks are a simple, yet effective method to locate the source of alarms and errors, and are often the quickest route to resolve a problem.

Several pre-defined codes (Inband, ESF FDL and USER) are available to loop up/down network elements and this can quickly identify impaired spans over a large area.



### Performance Analysis Summary

A detailed summary screen clearly displays the signal status and Pass/Fail criteria for each major performance parameter alerting the user to any problems. Color LEDs provide information about the current status of the instrument's receiver - indicators toggle from green to red when an alarm conditions occur. Summary indicators are coupled to the high level Alarm/Error LEDs which can be hidden or viewed depending on operator preference.



### View Rx Data

The DS1 receiver can be used to monitor a live T1 circuit for status and alarms throughout the network. The real-time View RX Data feature or ABCD bits display quickly help find timing and protocol problems in CAS type signaling protocols.

### ISDN PRI Testing

The option provides key functionality necessary for testing and troubleshooting T1 Primary Rate connections. Operating in TE or NT modes, the unit is able to setup and receive ISDN calls with user-defined parameters including call control protocol, called number and related facilities.

Protocol functions feature detailed signaling statistics, message monitoring and decode, and complete result presentation. Equipped with these capabilities, analysis of international and national ISDN, and other access protocols is possible.

### CSU/NIU Emulation

The unit incorporates CSU and NIU emulation which helps to isolate problematic T1 circuits. Loopback status, Code and Frame errors including Level measurements are presented in an easy to read table. Dedicated function buttons are immediately accessible to initiate different loopback commands.



## IP Testing

Triple Play services are IP centric, so IP test functions are no longer considered a luxury. On a daily basis, technicians verify network connections during service installation and restoration, so Ping test, Trace Route, ARP, Web browser, FTP throughput, VoIP Call emulation and IPTV measurement have become routine measurements. IP verification on the CX350S is possible over the DOCSIS Cable Modem and 10/100Base-T Ethernet test ports, while a subset of these tools is available using the USB WiFi adaptor.



## VoIP Testing

Take advantage of the three software options offering different test methods to verify and provision your VoIP network. Testing can be performed over any of the Ethernet or DOCSIS test ports.

**VoIP Check** – Simulates a VoIP call to the nearest router and measures the round trip MOS score and related VoIP parameters.

**VoIP Expert** – Generates industry standard wave files to verify MOS and R-factor values of upstream and downstream paths and includes QoS measurements such as packet jitter, packet loss, and delay. Compatible with all VeEX testers including VX1000 VoIP server software.



**VoIP Call Expert** – Emulates an IP phone and can place and receive calls using SIP or H.323 protocols. Comprehensive Codec support and call destination options verify voice encoding and translation provisioning. Real-time evaluation of subjective voice quality (MOS and R-factor) is made possible using the patented Telchemy® test method.



## IPTV Explorer

IPTV Service Providers nowadays have to ensure the transport layer and MPEG payload are both within defined limits, because simply checking packet loss, jitter and related impairments of the Ethernet distribution network is not enough to evaluate the quality of the IPTV content carried in the upper protocol layers. The IPTV Explorer option extracts the MPEG payloads from the Ethernet streams, decodes and displays them to check transport and programming content so that QoS and QoE can all be assessed.

*Note: this feature requires the Ethernet option.*

### Media-Stream-Based Algorithm

A proprietary and sophisticated algorithm analyzes the IP stream to assess and derive video quality and improve accuracy of quality scores.

- **Frame structure/GoP detection** – Identifies I, B and P frames in both unscrambled and encrypted video streams, to determine GoP length and the rate and distribution of packet loss in each frame
- **Per-frame quality computation** – Quality in each frame using the frame type, frame size, codec type, bandwidth and packet loss data. For P and B frames, TX300S models the loss propagated from earlier reference (I or P) frames
- **Bandwidth estimation** – the bandwidth used by certain types of video frames is analyzed to estimate the quantization level applied by the video encoder

### Program Identifier (PID) Statistics

PID statistics provide critical information about the MPEG transport stream. The bandwidth and packets associated with each individual stream are listed allowing the technician to check the video, audio and data content and to check for any “illegal” PIDs.

### Transmission Quality Score

QoS parameters are evaluated and presented in an intuitive manner so that technicians unfamiliar with MPEG signals are able to make accurate decisions to ensure maximum service availability.

- Audio and Video MOS scores associated with the particular video/audio codec used and transmission quality are reported
- VSTQ (Video Service Transmission Quality), is a codec-independent scoring that rates the ability of the network to reliably transport video
- ETSI TR 101 290 metrics are good indicator of transport associated errors

## WiFi Spectrum Analyzer



The CX350S offers a powerful portable spectrum analyzer on a USB dongle that displays all RF activity in the WiFi bands. With dual 2.4 GHz and 5 GHz bands support, the analyzer covers all 802.11a/b/g/n networks and is the ideal tool for enterprise environments with a mix of wireless technologies.

With multiple graphical format displays it helps to visualize and locate RF signals in the spectrums as well as locate and eliminate interference sources (cordless phones, microwave ovens, Blue-tooth devices, etc.), discover and remedy competing access points.

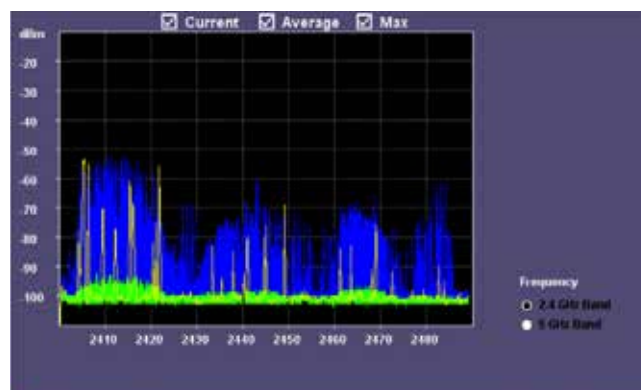

## WiFi InSSIDer

The WiFi InSSIDer provides the best tools for WiFi networks discovery and performance troubleshooting. With compatible USB WiFi adapter for 802.11 a/b/g/n wireless in 2.4 GHz and 5 GHz bands the InSSIDer provides a clear picture of the environment. It helps identify poor channel placement, low signal strength and interferences in easy to understand graphs and tables.

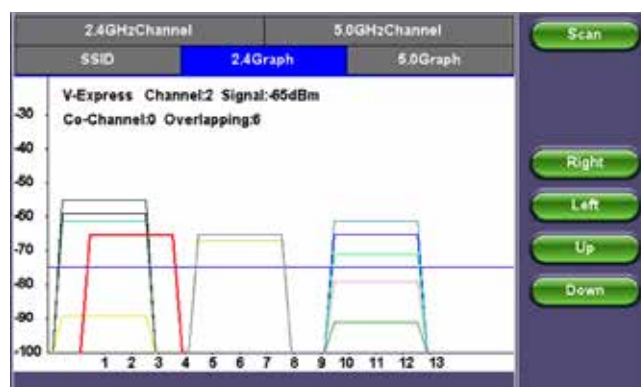

## WiFi Wiz

The WiFi Wiz function with USB WiFi adapter for 802.11 a/b/g/n wireless in 2.4 GHz and 5 GHz bands makes troubleshooting WiFi connectivity issues a simple task.

Scan for available networks and view all access points detailed information along with SSID, signal strength and channel allocation. Connect to Access Points with WEP/WPA or WPA2 encryption and verify IP capabilities to ensure the wireless network is properly installed and configured. A full suite of IP testing features is supported (ping, trace, web browser, etc.).

Tools	Scan	Connect	Network
	Ping	Trace Route	ARPWiz
IP Tools	AP List		
Net Wiz	WiFi Scan Finished		
WiFi Wiz	ESSID	BSSID	Channel
Advanced	VeEX Office	00:1A:DD:A5:51:C1	1
Browser	Protected via WEP		
	VeEX-CX180	00:24:B2:C0:92:2C	1
	Protected via WPA2		
	VeEX_38	00:16:B6:51:17:4A	6
	Protected via WPA2		
	UX100	00:22:75:53:BD:7E	6
	Protected via WPA2		
Utilities	VeEX-Mktg14	9C:D3:6D:AC:9C:3E	11
Files	Protected via WPA2		

## VeSion R300 Productivity Server

A software application specifically designed for medium-to-large CATV operators facing the enormous challenge of coordinating hundreds of installations per day, collecting the field test results for billing/record purposes and having to maintain a large inventory of test sets in parallel. When used in conjunction with the Home Installation Process (HIP) and Signature Pad features, the application becomes a powerful tool to reduce customer call-backs and associated truck rolls, maximizing workforce efficiency and lowering operational costs.

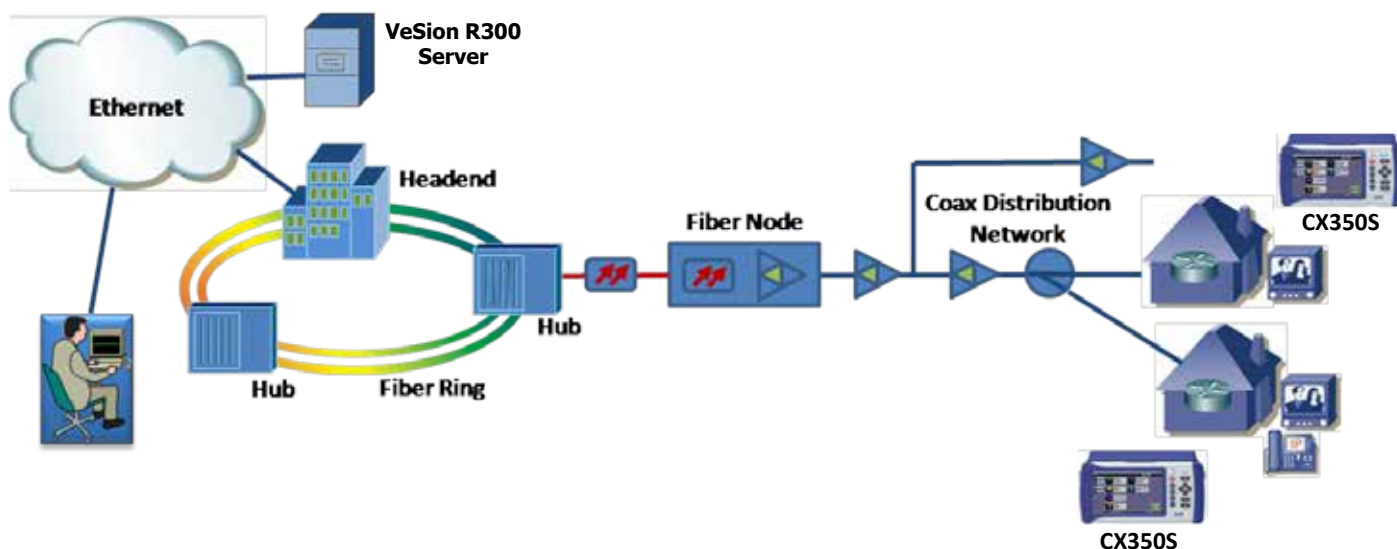

### Home Installation Process (HIP)

A customized test procedure that can be downloaded and programmed into each test set. The step-by-step script eliminates guesswork and rogue installation practices ensuring consistent service turn-up and delivery. This disciplined technique ensures the “Birth Certificate” of each new installation conforms to operating guidelines and ISO quality standards.

### Advanced Management

Authorized test sets register with specific VeSion R300 Server/s to download new channel tables, test profiles, measurement thresholds and job cards. Test results can be uploaded via LAN interface or DOCSIS connection running over the existing RF network. Signature Pad electronically captures the customer signature which is automatically appended to the test results upon work order completion.

### Benefits

- Centralized storage of test profiles, software versions, and measurement thresholds
- Registered test sets are informed of new test profiles, software versions and channel tables
- Test set software versions are maintained and synchronized
- Results are collected electronically while technician is on site, thus billing transactions can be processed sooner
- Operates with Operator and Contractor owned test sets giving operational statistics for both activities
- Provides theft prevention, test set lockout, time lock and other security features

### ReVeal CX300 PC Software

A software package shipped standard with each CX test set. Channel tables, location thresholds, and other installation data can be created and edited on a PC for upload to the test set via USB, LAN or DOCSIS connection. Test results can be downloaded and saved to a PC, where test data management and report generation can be performed. Users are able to check and upgrade their test sets without having to return the unit to the supplier, thus reducing downtime.



## Specifications

### General

Input Impedance: 75Ω

Frequency Range: 5 MHz to 1 GHz

### Analog Channel Measurement

Level Range: -45 dBmV to +55 dBmV

Level Accuracy: ± 1.5 dB

Level Resolution: 0.1 dB

Standards: NTSC, PAL, SECAM

Channels: Video, Audio 1 and Audio 2, and FM V/A1, V/A2 Adjacent, C/N, HUM

### Digital Channel Measurement

Level Range: -45 dBmV to +55 dBmV

Level Accuracy: ± 1.5 dB

Level Resolution: 0.1 dB

Modulation: QAM 64/256, J.83 Annex A/B/C

Symbol Rate: 1 to 7 MHz programmable

Constellation Display: QAM 64/256 with zoom

Minimum QAM Locking Level: -15 dBmV

MER Range: 21 dB to 40 dB, ± 1.5 dB typical

Pre & Post BER Range:  $1 \times 10^{-9}$  to  $9 \times 10^{-3}$

Errored and Severely Errored Seconds

Histogram Analysis: up to 60 min per minute and per second

- MER, Pre BER, Post BER, Errored Sec, Severely Errored Sec

Advanced Digital Measurements (option)

- DFE and FFE gain/tap
- Group Delay Peak to Peak (ns)
- MaxAC (dB)
- Phase Jitter (°)
- Symbol Rate Error (ppm and Hz)
- Frequency Error (ppm and Hz)
- Frequency Response Peak to Peak (dB)
- HUM (%)
- EVM (%)
- Carrier to Noise (C/N)
- Carrier to Ingress (C/I)

### Spectrum Analysis

Reverse Scan Range: 5 to 65 MHz

Forward Scan Range: 55 to 1000 MHz

Range: -45 to +55 dBmV

Dynamic Range: 50 dB

RBW: 125, 330, 1000 kHz

Attenuation: 0 to 50 dB, 5 dB/step

### Other Measurements

System Scan: typical 30 seconds per channel table

Tilt: 8 Analog plus 8 Digital channels

Programmable Pass/Fail Threshold: 10 sets

Programmable Channel Table: 20 tables

## Options

### Cable Modem

DOCSIS/EuroDOCSIS 3.0/2.0/1.1 compliant

Downstream/Receiver

- Demodulation: QAM 64/256/1024
- Frequency Range
  - DOCSIS: 88 MHz to 1002 MHz
  - EuroDOCSIS: 108 MHz to 1002 MHz
- Maximum Speed: 320 Mbps (EuroDOCSIS with 8 D/S bonding)
- Channel Bonding: Up to 8 channels (contiguous or non-contiguous)
- Bandwidth
  - DOCSIS: 6 MHz
  - EuroDOCSIS: 8 MHz
- Input Power Level: -15 dBmV to +15 dBmV

Upstream/Transmitter

- Modulation: QPSK, QAM 8/16/32/64/128
- Frequency Range
  - DOCSIS: 5 to 42 MHz
  - EuroDOCSIS: 5 to 65 MHz
- Maximum Speed: 160 Mbps (EuroDOCSIS with 4 U/S bonding)
- Channel Bonding: Up to 4 channels
- Output Signal Level
  - QAM 32/64: +8 to +54 dBmV
  - QPSK: +8 to +58 dBmV
  - S-CDMA: +8 to +53 dBmV

General

- IPv4 and IPv6 support
- DHCP client obtains IP and DNS server address from DHCP server automatically
- Time of Day (ToD) support for local & MSO time synchronization
- TFTP Client support for cable modem configuration file download
- Security: BPI+ and AES support
- Pass-Through testing (1000BaseT port): Verify high bandwidth data transfer between PC and Network

### Return Path QAM Analysis

Modulation: QPSK, QAM 16/64/128/256

Symbol Rate: 1.28 MHz, 2.56 MHz, 5.12 MHz, programmable

Minimum QAM Locking Level: -15 dBmV typical

Constellation Diagram

MER Range: 22 dB to > 40 dB, ± 1 dB

Adaptive Equalizer Display

Pre & Post BER Range:  $9 \times 10^{-3}$  to  $9 \times 10^{-9}$

Errored and Severely Errored Seconds

### Upstream Signal Generator

Modulation Type: CW, QPSK, QAM 16/64/128/256 Annex A/B

Symbol Rate: 1.28 MHz, 2.56 MHz, 5.12 MHz, programmable

Frequency Range: 5 to 65 MHz

Level Range: 8 to +58 dBmV; Level Accuracy: ± 1 dB

Level Adjustable Step: ± 1 dB

Frequency Adjustable Step: 250 kHz/step

Frequency Accuracy: 5 ppm

Settling Time: less than 5 ms

Forward Error Correction (FEC): Continuous

**TDR**

Range: 2 km / 6,000 ft  
 Range Selection: Manual range control  
 Accuracy: 1% of selected range  
 Resolution: Approximately 1% of range  
 Velocity Factor: Adjustable from 1% to 99%  
 Output Pulse Width: 3 ns to 3 ms, automatic with range  
 Output Pulse: 5 Volts peak-peak (into an open circuit)  
 Output Impedance: Selectable 25, 50, 75 and 100  $\Omega$   
 Scan Rate: 2 scans/second

**Ethernet****Interfaces**

Single 10/100/1000Base-T Ports: RJ45 connector, IEEE 802.3 compliant  
 Single 1000Base-X SFP Ports: SFP, LC connector

**1000Base-SX**

Wavelength: 850 nm  
 TX level: -9 to -3 dBm  
 RX level sensitivity: -20 dBm  
 Max reach: 550 m  
 TX bit rate: 1.25 Gbps  
 RX bit rate: 1.25 Gbps  
 Jitter Compliance: According to IEEE 802.3 recommendations  
 Ethernet Classification: According to IEEE 802.3 recommendations  
 Eye Safety: Class 1

**1000Base-LX**

Wavelength: 1310 nm  
 TX level: -9.5 to -3 dBm  
 RX sensitivity: -22 dBm  
 Max reach: 10 km  
 TX bit rate: 1.25 Gbps  
 RX bit rate: 1.25 Gbps  
 Jitter Compliance: According to IEEE 802.3 recommendations  
 Ethernet Classification: According to IEEE 802.3 recommendations  
 Eye Safety: Class 1

**1000Base-ZX**

Wavelength: 1550 nm  
 TX level: 0 to +5 dBm  
 RX sensitivity: -22 dBm  
 Max reach: 80 km  
 TX bit rate: 1.25 Gbps  
 RX bit rate: 1.25 Gbps  
 Eye Safety: Class 1

**Ethernet Features**

Auto Negotiation  
 Full and Half Duplex  
 Flow Control

**Modes of Operation**

Terminate  
 Monitor  
 Pass through  
 Loopback

**Traffic Generation**

IEEE 802.3 and Ethernet II (DIX) frames  
 Configurable MAC, Ethernet Type, VLAN, MPLS, IP, UDP header fields  
 Constant, Ramp, and Burst traffic profiles with configurable bandwidth % utilization  
 Jumbo Frame Support (10,000 bytes)  
 Fixed, multiple, and random frame size generation  
 Traffic prioritization via VLAN priority field, MPLS CoS field and the IP TOS/DSCP fields  
 Up to 3 VLAN and MPLS tags can be added to each user configured traffic stream

**RFC2544 Compliance Testing**

Automated tests with configurable threshold values and maximum transmit bandwidth settings  
 Throughput, Latency, Frame Loss, and Back-to-Back (burst) tests  
 Frame sizes: 64, 128, 256, 512, 1024, 1280, and 1518 bytes including 2 user configurable frames

**Bit Error Rate Testing**

Patterns: PRBS 2<sup>31</sup>-1, PRBS 2<sup>23</sup>-1, PRBS 2<sup>20</sup>-1, PRBS 2<sup>15</sup>-1, PRBS 2<sup>11</sup>-1, CRPAT (Layer 1 only), CSPAT (Layer 1 only), CRTPAT (Layer 1 only), Normal and inverted patterns  
 Error Injection: Bit, CRC, Symbol, IP Checksum  
 One configurable stream with one fixed frame size

**Traffic Filters**

Up to eight traffic filters can be configured with MAC, VLAN, and IP fields for Monitor and Loopback modes

**Multiple Streams Throughput Testing**

Up to eight independent traffic streams with configurable MAC, VLAN, MPLS, and IP fields including traffic prioritization via the VLAN tag priority field and the IP header TOS/DSCP field  
 % of bandwidth allocation is configurable for each stream  
 Different traffic profiles (constant, ramp, or bursty) may be configured for different streams  
 Different frame sizes are user configurable per stream

**Smart Loop**

Layer 1: loops back all incoming traffic  
 Layer 2: all incoming unicast traffic is looped back with MAC source and destination addresses swapped  
 Layer 3: all incoming unicast traffic is looped back with MAC and IP source and destination addresses swapped  
 Layer 4: all incoming unicast traffic is looped back with MAC, IP, and UDP/TCP ports swapped

**Key Measurements**

Error Measurements: Bit, CRC, symbol, IP checksum, jabber frames, runt frames, collisions, late collisions  
 Alarm Detection: LOS, pattern loss, service disruption  
 Frame/Packet Statistics: Multicast, broadcast, unicast, pause frames, frame size distribution, bandwidth utilization, frame rate, line rate, data rate, frame loss, frame delay variation

## IP Testing

Ping, Trace Route, ARP, FTP/Web tests, Web-browser. These tests are done via the chassis 10/100-T port, Cable Modem emulation or USB WiFi adaptor. Also supports VeTest, a throughput test, in Cable Modem emulation mode.

## VoIP Testing

*Requires Cable Modem or Ethernet option*

VoIP Check

- Simulates VoIP call to the nearest router/CMTS
- Round Trip MOS score

VoIP Expert

- MOS and R-factor measurement
- Packet Statistics: packet loss, jitter, delay

VoIP Call Expert

- VoIP call setup with VoIP USB adaptor
- Supports SIP and H.323 protocols

Codec: G.711U, G.711A, Optional G.723, G.729

## IPTV

*Requires Ethernet option*

Mode: Monitor

Stream configuration: Unicast, multicast, IP address, Port number

Codecs: MPEG2, MPEG4 (Part2) and MPEG4 Part10 (H.264)

Probe function with streams auto-detection

IPTV image viewer for channel identification (does not decode encrypted streams)

Stream Analysis

- PIDs count
- PID MAP
- Transport Error count
- Data rates: Video, Audio, Data (Bandwidth and Packet Counts)

Video Analysis

- MOS\_Video, Video Service Transmission Quality (VSTQ), Estimated Peak Signal to Noise Ratio (EPSNR ATIS)
- I/B/P Frame statistics (Bandwidth, # Frames Received, Lost, Impaired)

Audio Analysis

- MOS\_Audio

TR 101 290 Metrics

- Sync loss, sync byte error, PAT/PAT2 error, Continuity error, PMT/PMT2 error, PID error, transport error, CRC error, PCR discontinuity, PCR accuracy error

## WiFi Wiz

Requires compatible USB WiFi adapter for a/b/g/n networks in 2.4 GHz and 5 GHz bands

Access Points scan with signal level and link quality measurement

WEP/WPA1/WPA2 encryption

IP Connectivity test (Ping, trace route, ARPWiz, Web browser)

Provides Wi-Fi LAN access to the test set (e.g. VeExpress, R-Server, Remote Control, ReVeal)

*Requires Wi-Fi USB transceiver*

## WiFi InSSIDer

Requires compatible USB WiFi adapter for a/b/g/n networks in 2.4 GHz and 5 GHz bands

Network scan results in Graphical or table format

Lists: Network names, BSSID, encryption type, channel allocation, signal strength, co-channels and overlapping channels

*Requires Wi-Fi USB transceiver*

## WiFi Spectrum Analyzer

Supports 802.11 a/b/g/n

Frequency Range: 2.400 to 2.495 GHz and 5.150 to 5.850 GHz

Amplitude Range: -100 to -6.5 dBm

Antenna: RP-SMA

Planar, topographic, spectral view

*Requires Wi-Fi Spectrum Analyzer USB dongle*

## T1 Testing

### Interfaces

Dual Bantam (100Ω balanced)

Rates and line code: 1.544 Mbps, AMI & B8ZS

Compliant to ITU-T G.703, G.823, G.824, G.772 and ANSI T1.102 recommendations where applicable

Clock recovery (pulling range) per ITU-T G.703

Receiver Sensitivity

For 1.544 Mbps (DS1)

- Terminate: ≤ 6 dB (cable loss)
- Monitor (PMP): ≤ 26 dB (20 dB resistive, 6 dB cable loss)
- Bridge: ≤ 6 dB (cable loss)

### Clock Synchronization

Internal: ± 3.5 ppm stability per ITU-T G.812

Recovered: from the incoming signal

External reference via RX2 balanced

- Signal: 1.544 Mbps (B8ZS)

Tx Frequency Offset

- Up to 50 ppm in steps of 0.1 ppm for electrical interfaces

### Operating Modes

Terminate mode

Monitor mode

Bridge

### Signal Structure

1.544 Mbps (DS1)

- Unframed or Framed SF (D4), ESF per ANSI and Telcordia standards where applicable
- Test signal in N x 64 kbps, N x 56 kbps where N=1 to 24

### Patterns

The following test patterns can be generated

- PRBS: 2<sup>7</sup>-1, 2<sup>9</sup>-1, 2<sup>11</sup>-1, 2<sup>15</sup>-1, 2<sup>20</sup>-1, 2<sup>23</sup>-1, 2<sup>31</sup>-1, QRSS: normal or inverted
- Fixed: 0000, 1111, 1010, 1000, 1100

### Errors

Insertion

- 1.544 Mbps (DS1): Code, FAS, Bit, CRC

Measurement

- 1.544 Mbps (DS1): Code, FAS, Bit, CRC

### Alarms

Generation

- 1.544 Mbps (DS1): AIS, yellow, LOS, LOF
- Mode: Static (Enable/Disable)

Measurement

- 1.544 Mbps (DS1): LOS, AIS, LOF, AIS, yellow, idle and LSS

### Test Results

Error count, ES, %ES, SES, %SES, UAS, %UAS, EFS, %EFS, AS, %AS, and rate for all events: errors, alarms and pointer events



## Performance Analysis

Measurements according to:

- ITU-T G.821 recommendation: ES, EFS, SES and UAS with HRP 1% to 100%
- ITU-T G.826 recommendation: EB, BBE, ES, EFS, SES, UAS; HRP of 1% to 100%
- In service measurement (ISM) using FAS, CRC or Code
- Out of Service measurement (OOS) using bit errors (TSE)
- ITU-T M.2100 recommendation: ES, EFS, SES, UAS with HRP 1% to 100%
- User defined thresholds for Maintenance (MTCE) and Bringing into Service (BIS) objectives
- User defined thresholds for Maintenance (MTCE) and Bringing into Service (BIS) objectives. In service measurements on both near and far ends of path using TSE

## ISDN PRI Testing

Bidirectional monitoring and call analysis

National ISDN, AT&T Custom, and Northern Telecom DMS compatible NT and TE emulation

Voice and data call setup and receive

Data Call BERT measurement

Via Headset for B-channel talk/listen

Supports multirate N x 64 k data call

## Common Functions and Measurements

### Frequency Measurement

Electrical Interfaces: Hz & bit/s in ppm

Resolution: 1 Hz

### Event Logging

Date and time stamped events in tabular format

### Histograms

Available for all interfaces

- Display of Errors and Alarms versus time
- Resolution: Seconds, minutes, hours and days

### LED Indicators

Fixed LEDs for Signal, Framing, Pattern and Errors/Alarms

Soft LEDs for DS1 Alarms/Errors displaying historical events and conditions

## General Specifications

Size	11.40 x 5.50 x 2.60 in (W x H x D) 290 x 140 x 66 mm
Weight	Less than 5.5 lb (less than 2.5 kg)
Battery	Lilon smart battery 5200 mAh 10.8VDC
Battery Operating Time	> 4 hours continuous measurement > 9 hours idle
AC Adaptor	Input: 100-240 VAC, 50-60 Hz Output: 15VDC, 6A
Operating Temperature	32°F to 113°F (0°C to 45°C)
Storage Temperature	-4°F to 158°F (-20°C to 70°C)
Humidity	5% to 95% non-condensing
Display	TFT 7" full color touch-screen display
Ruggedness	Survives 3 ft (1 m) drop to concrete on all sides
Interfaces	USB 2.0, RJ45, 10/100-T Ethernet, Bluetooth 2.0 (optional)
Languages	Multiple languages support