



VePAL CX380S-D3 Super-Tech Maintenance Tool for CATV

CATV Network Testing Simplified

VeEX® VePAL CX380S-D3 is a next generation test solution designed for analog and digital cable TV networks with enhanced spectrum analysis, digital channel, DOCSIS, Sweep, MPEG analysis and Ethernet test capabilities.

Platform Highlights

- Robust, lightweight chassis packed with powerful features for demanding environments and test conditions
- High resolution color 7" touch-screen with graphical user interface
- Ethernet LAN management port for remote control, back office applications and workforce management
- Fast and efficient test result transfer to USB memory stick or FTP upload via LAN, DOCSIS, USB WiFi, USB data modem or USB Bluetooth
- Maintain instrument software, manage test setups and channel tables, process measurement results and generate customer test reports using included ReVeal™ PC software
- Extend field testing time using interchangeable Lilon battery pack/s
- Ability to lock user interface to prevent unwanted human interference during long-term testing
- WiFi Wiz with InSSIDer SSID Analysis*
- WiFi Spectrum Analyzer*
- VoIP and IPTV*

Key Features

- Frequency range from 5 MHz to 1 GHz
- Comprehensive SLM measurements (Single Channel, System Scan, Tilt and Installation Check)
- Annex A, B, C support
- True Spectrum Analyzer with 30 ms sweep time to capture fast transient and impulse noise
- MPEG Explorer: QAM channel MPEG-TS analysis*
- Upstream Generator* (CW, QPSK, QAM 16/64/128/256 modulation)
- Forward and Return path QAM measurements (MER, Pre/Post BER, Constellation diagram, Histogram and Equalizer on/off mode)
- Advanced Digital measurements* (HUM, EVM, Phase Jitter, Symbol Rate Error, Frequency Response, Group Delay)
- Dual band DOCSIS 3.0 certified Cable Modem with 8x4 Channel Bonding*
- DOCSIS 3.0 certified Cable Modem with up to 24x8 Channel Bonding*
- FCC POP including Digital POP*
- Ethernet up to GigE with SLA validation tests including BERT, Throughput, RFC2544 and Y.1564 SAM
- Headend Check auto test for the entire selected Channel Table lineup*
- VeTest Throughput*
- QAM Wiz DOCSIS Burst Demodulator*

*Optional features

SLM Features

Single Channel Measurement

Analog and digital carriers are very different in terms of signal content and power distribution and thus require the advanced SLM techniques supported in the CX380S-D3.

In **analog** mode, video and audio levels, V/A, Gated C/N, Adjacent channels, gated CSO, CSO/CTB and HUM are measured.

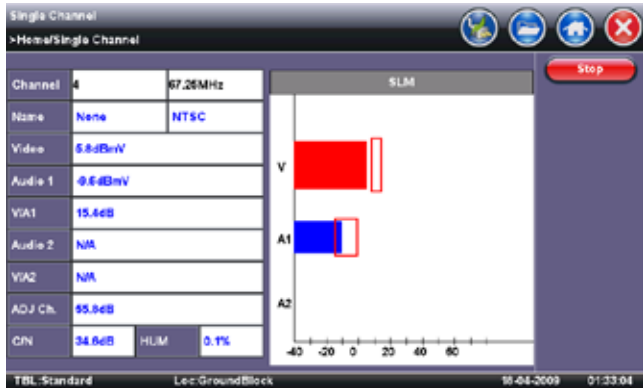

In **digital** mode, average power, MER, Pre-BER, Post-BER, Error seconds and constellation diagram are displayed. User programmable location thresholds and test point compensation are useful utilities enabling fast, simple and automated testing of carrier signals.



Advanced Digital Channel Analysis

Digital pictures do not show signal impairment until it is too late because the margin between acceptable quality and failure is quite small.

Constellation diagrams – A valuable tool to help detect the presence of noise, phase jitter, interference, gain compression, laser clipping and ingress, all of which impact overall signal quality and thus reduces Modulation Error Ratio (MER). The Advanced Digital Analysis option has added in depth analysis of a QAM carrier with Phase Jitter, Group Delay, Symbol rate error, Frequency error, Maximum Amplitude Change, HUM, C/I, C/N and Frequency response measurements.

Adaptive Equalization – The built-in equalizer does a great job of improving MER of a QAM signal, but it is also important for technicians to know how hard the system is working to ensure adequate margin for system degradation. The adaptive equalizer in the CX380S-D3 can be turned off to make troubleshooting marginal amplifiers, ingress, CPD and related impairments easier.

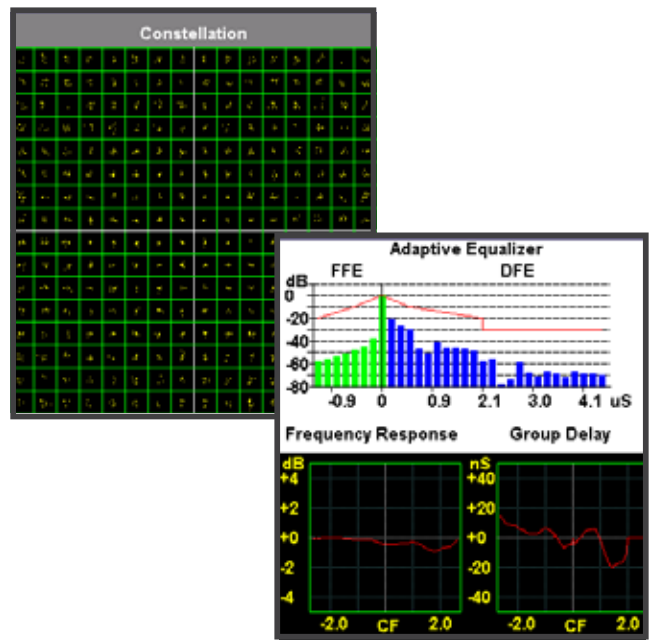

System Scan

Within seconds, all analog and digital channels at a service location are measured. Signal parameters including channel number, channel name, frequency, modulation type and power levels are measured. Signal degradation or tilt can be easily pinpointed using on-screen markers and the zoom mode.

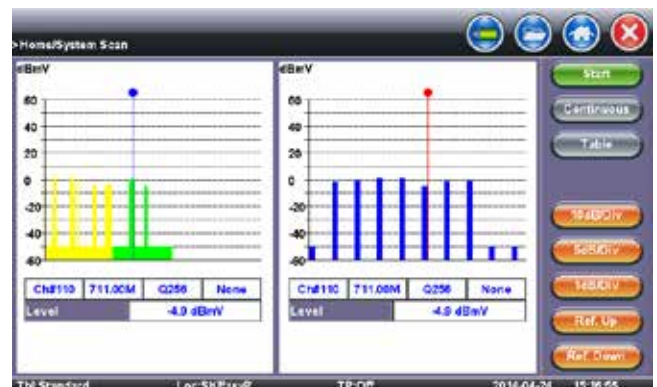

SLM Features *cont'd*

Histogram Analysis

Noise impulses can suddenly disrupt a digital carrier but it's difficult to detect without monitoring the carrier over a period time.

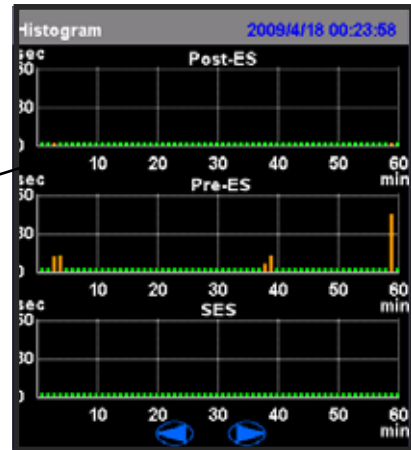

The histogram feature records level, MER, Pre-BER, Post-BER and Error Seconds on per second time bucket for up to 60 minutes. The results are shown in graphical format that allows easy correlation of measured parameters down to one-second resolution.

Tilt

Tilt measurements identify distortion over the frequency range allowing technicians to apply correct equalization or compensation to the HFC network. Up to eight analog signals and digital carriers including DOCSIS channels can be predefined on a channel table and selected to perform the tilt measurement. The measurement can be performed between the lowest and highest channel or any user selectable channel by tapping the applicable bar on screen.

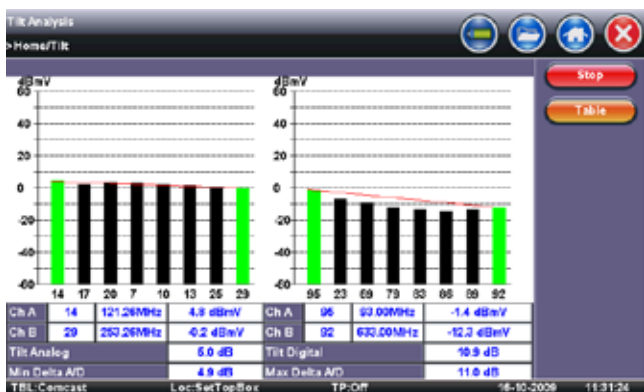

Installation Check

Up to 16 analog and 16 digitals are checked against preset location thresholds. The feature is particularly useful to verify and turn up of service at new installations or after service is restored, Pass and fail conditions are color coded for easy interpretation and test results are clearly displayed. This automatic test procedure adds consistency to the final service qualification. The CX380S-D3 can store up to 20 channel tables each of which can be pre-programmed with channels to be used for installation check.

FCC POP

Proof of Performance tests are required by the FCC for MSOs to periodically prove their analog networks are within specified guidelines for performance. Carriers' networks evolving to all-digital necessitates Digital POP tests.

The optional FCC POP Feature consists of various Auto Tests, including Digital POP and 24-Hour Analog Levels. Test Channels are based on a user configurable Channel Table. Standard test results are supported in both CSV and PDF Formats.

Digital POP Part I				Digital POP Part II			
Channel	Freq (MHz)	Name	Level (dBmV)	MER (dB)	Pre-BER	Post-BER	Freq Resp (dB)
83	459.00	D2B1	7.8	39.3	0.0e+00	0.0e+00	2.3
83	629.00	None	7.4	39.3	0.0e+00	0.0e+00	0.7
94	646.00	None	8.8	39.0	0.0e+00	0.0e+00	2.5
95	651.00	None	8.4	39.3	0.0e+00	0.0e+00	3.0
95	657.00	None	6.4	30.4	0.0e+00	0.0e+00	2.0
97	663.00	None	8.8	39.2	0.0e+00	0.0e+00	2.1
98	669.00	None	7.1	39.4	0.0e+00	0.0e+00	2.0
99	675.00	None	7.0	39.2	0.0e+00	0.0e+00	1.7
100	681.00	None	8.8	39.8	0.0e+00	0.0e+00	1.3

Headend Check

This optional feature tests all channels configured in the Channel Table, reporting Level, MER and BER per channel.

True Spectrum Analyzer

The CX380S-D3 offers a true Spectrum Analyzer, vastly superior to SLM-based measurements found in typical field meters. It incorporates advanced DSP technology to capture transient ingress across a wide 5 MHz to 1000 MHz frequency range, with 60 dB dynamic range. Adjustable sweep time, RBW and VBW settings optimize signal representation and noise floor performance.

The large 7" high resolution TFT LCD features a fast refresh rate, preserving and displaying the finest spectrum details. Touch-screen control allows rapid on-the-fly changing of test parameters and simplifies measurements while horizontal and vertical markers and min/max hold displays signal values instantly and varying signal parameters over time.

Test profiles consisting of user-settable parameters such as CF, Span, RBW, VBW and Marker positions can be saved and recalled for repeated testing. Waveform storage enables a user to compare and contrast a captured signal versus a current measurement, in both superimposed or split screen views.

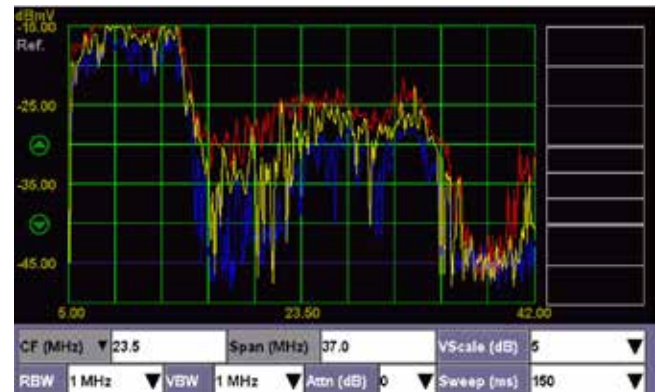

QAM Wiz: DOCSIS Burst Demodulator

The optional QAM Wiz DOCSIS Burst Demodulator helps identify rogue Cable Modems that contribute harm to the plant. QAM Wiz does the following:

- Captures all available Upstream Channel Descriptors provided by the CMTS from a specific downstream DOCSIS channel.
- For a selected UCD, captures and demodulates burst Cable Modem signals.
- Assesses QAM health for the UCD by measuring Upstream MER, burst constellations, codeword error rates and Equalizer Taps.
- Identifies associated Cable Modem MAC Addresses, which helps identify rogue Cable Modems.



MPEG Explorer

Cable Operators nowadays have to ensure that both the RF characteristics and digital payload of their QAM carriers are within defined limits, and simply viewing the QAM carrier “hay stack” is not enough to evaluate the protocol layer. The CX380S-D3 MPEG Explorer option extracts MPEG Transport Stream payloads from the QAM carrier and decodes them to check transport and programming content. A real-time output (ASI) allows access to the data stream for further analysis.

Media-Stream-Based Algorithm

A proprietary and sophisticated algorithm analyzes the IP stream to assess and derive video quality and improve accuracy of quality scores.

- **Frame structure/GoP detection** – Identifies I, B and P frames in both unscrambled and encrypted video streams, to determine GoP length and the rate and distribution of packet loss in each frame.
- **Per-frame quality computation** – Quality in each frame using the frame type, frame size, codec type, bandwidth and packet loss data. For P and B frames, CX380S-D3 models the loss propagated from earlier reference (I or P) frames.
- **Bandwidth estimation** – the bandwidth used by certain types of video frames is analyzed to estimate the quantization level applied by the video encoder.

Type	PID Count	Mbps	BW %	PAT Count
Video	10	32.6	82	4857085
Audio	16	5.8	14	28320
Tables	2	0.2	1	592
Others	5	0.7	6.2	1238

Program Identifier (PID) Statistics

PID statistics provide critical information about the MPEG transport stream. The bandwidth and packets associated with each individual stream are listed allowing the technician to check the video, audio and data content and to check for any “illegal” PIDs. Identification of uncorrected packet errors provides valuable clues to picture impairments.

Transmission Quality Score

MOS scores associated with the particular video/audio codec used and transmission quality are reported. **VSTQ** (Video Service Transmission Quality), is a codec-independent scoring that rates the ability of the network to reliably transport video.

Metric	Value
VSTQ	42
EPSNR	60dB
EPSNRATIS	62dB

Quality of Service (QoS) Measurements

QoS parameters are evaluated and presented in an intuitive manner so that technicians unfamiliar with MPEG signals are able to make accurate decisions to ensure maximum service availability. To compare quality in different video service types such as HDTV and SDTV, both Absolute and Relative MOS scores are reported:

Perceptual Quality Metrics

- **MOS-V** – Video MOS, a score that considers the effects of the video codec, frame rate, packet loss distribution and GoP structure on video quality.
- **MOS-A** – Audio MOS, a score that considers the effects of the audio codec, bit rate, sample rate and packet loss on viewing quality.
- **MOS-AV** – Audio-Video MOS, a score that considers the effects of both picture and audio quality and the audio-video synchronization on the overall user experience.
- **Absolute MOS-V** – considers the image resolution, frame rate, codec and compression level, the effects of transmission impairments and frame loss concealment, but not the physical size of the display.
- **Relative MOS-V** – a MOS score relative to the ideal for the particular codec and image resolution in use.

I/B/P Frame Statistics

Packet loss in the video stream may or may not be apparent to viewers, depending on whether encoding errors affect I, B or P frames in the Group of Pictures. To accurately assess Quality of Experience (QoE), it is necessary to know which frame types were affected.

Detailed statistics for each frame type (I, B, P), including the number of received, lost and discarded frames and the proportion of each frame type impaired by packet loss and discard are reported. These metrics can be useful for troubleshooting and can help determine which GoP type and length should be used to obtain the best performance from the video service.

TR 101 290 Support

The ETSI TR 101 290 recommendation is a very good indicator of when a MPEG Transport Stream has been transported error-free across a network. The MPEG Explorer option features a dedicated measurement tab displaying Priority 1 alarms which are key indications of synchronization, continuity errors and major table errors while Priority 2 impairments which include transport error indicators, Cyclic Redundancy Check (CRC), errors in elementary streams and PCR timing impairments are also displayed.

Indicator	Count
Sync Loss	0
Sync Byte	0
PAT	0
PAT2	0
Continuity	2
PMT	1
PIG	1
Transport	1
CRC	0
PCR	0
PCR Repetition	0
PCR Discontinuity	0
PCR Accuracy	0
PTS	1
CAT	1

Upstream Signal Generator (USG)

Evaluate the bandwidth and noise performance characteristics of the reverse path with a choice of CW, QPSK, 16 QAM, 64 QAM and 128 QAM modulation types using industry standard symbol rates. Transmitting a known reference signal between 5-65 MHz (Annex A) or 5-42 MHz (Annex B) into the reverse path at a user defined power level and modulation, allows a technician to evaluate phase and amplitude distortions resulting from any misalignment present in the network. Injected reference signals can be used to determine the headroom in the reverse path and to identify laser clipping resulting from signal overload.

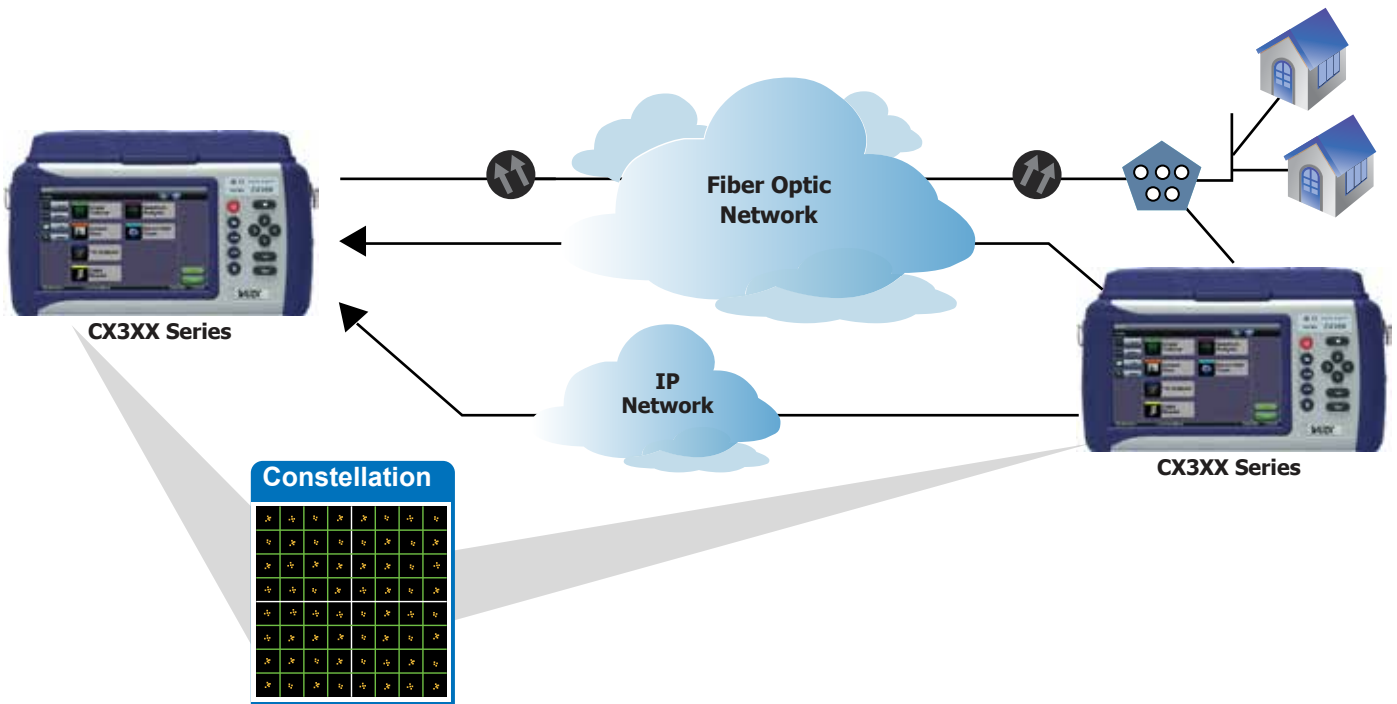

The USG function fitted with Forward Error Correction (FEC) capability, is compatible with the Return Path analysis options found on other VeEX products, including the CX180R RPM System, CX3XX Series and CX150-D3+ CATV test sets, as well as select 3rd party CATV QAM analyzers. Depending on the companion analyzer used, Digital channel power, MER (equalized and unequalized), Pre/Post FEC, EVM, Phase Jitter, Hum, Group Delay and Symbol rate errors can all be evaluated. These tests are invaluable to characterize the in-channel flatness, in-channel group delay and adaptive equalizer operation.

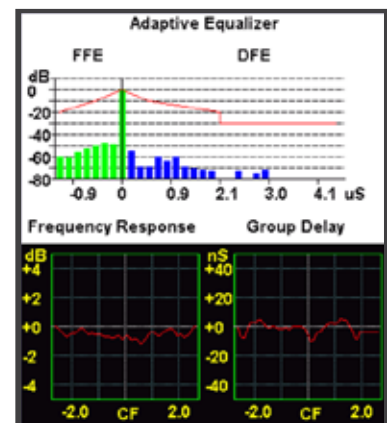

Return Path Sweep

The CX380S-D3 incorporates a sweep transmitter (USG) capable of generating sweep tones over a 5 MHz to 65 MHz frequency range with 125 kHz resolution, and amplitude levels ranging from 0 to 58 dBmV with 1 dB resolution.

When paired with a companion CX380 Series handheld unit or a CX180R RPM System located in the Headend, the entire return path frequency spectrum can be precisely characterized for DOCSIS 3.0 communications. Protection “Guard Bands” can be pre-configured to prevent test tones interfering with active DOCSIS transmissions.

The sweep system communicates the user defined sweep tables and measured test data over the Internet, freeing up valuable downstream bandwidth typically used by conventional telemetry systems found in competitor systems.

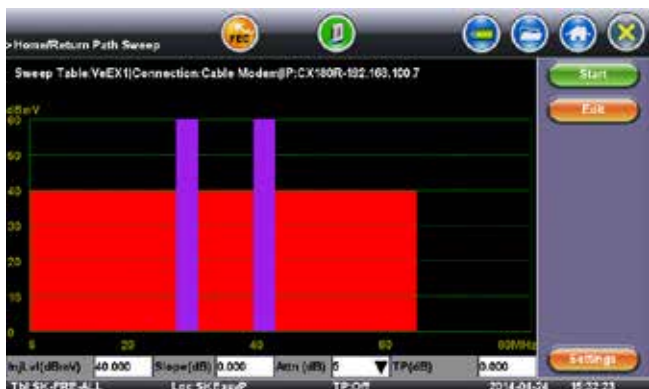

Remote View

Return path troubleshooting and testing is simplified when the CX380 Series is equipped with the Remote View option.

Utilizing a wired (10/100BaseT or DOCSIS) or wireless (3G UMTS or 802.11 WiFi) Internet connection, a technician operating the unit in the field is able to view real time measurements being performed by the companion CX380 Series or CX180R RPM System located in an upstream Node or Headend itself.

Developed specifically for dual ended test applications, evaluating MER, BER and Constellation and other advanced measurements like group delay and frequency response is extremely fast and convenient. In addition to sweep, real-time return path ingress measurements performed in the Headend by the CX380S-D3 or CX180R spectrum analyzer can also be viewed, thus making it a truly unique solution for upstream testing and characterization.

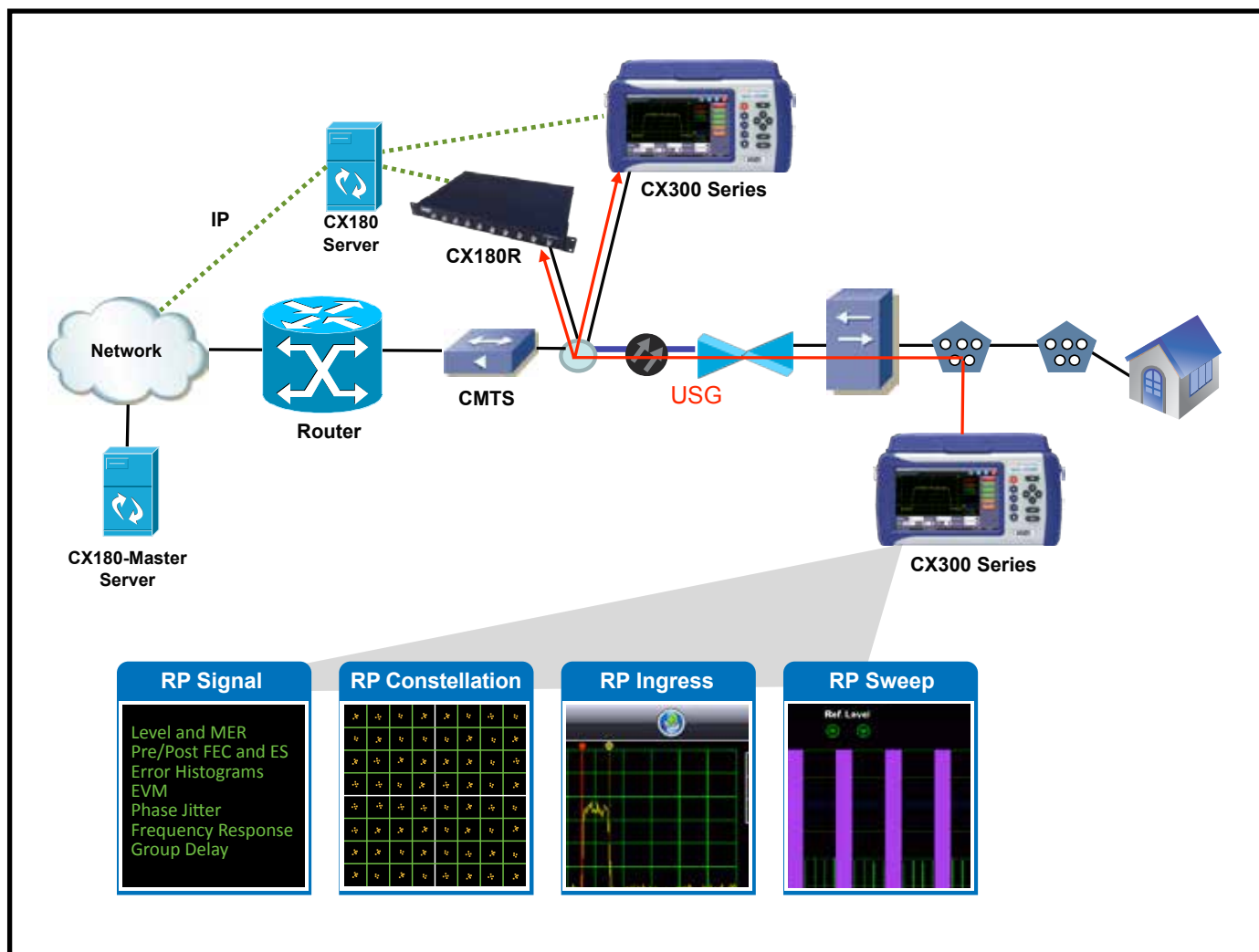
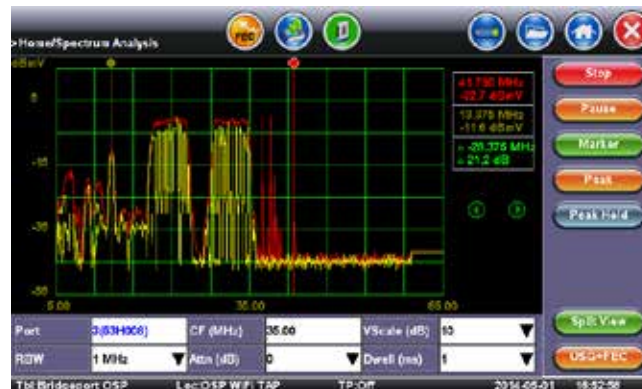

DOCSIS® 3.0

DOCSIS 3.0 Modem Emulation

Equipped with a CableLabs® certified 8x4 Cable Modem based on latest generation DOCSIS 3.0 technology, the CX380S-D3 enables technicians to perform dual band RF connection tests, without having to carry a separate test modem on service calls.



Intuitive Results

At a glance, the technician is able to view a summary of the ranging and registration process, check AES and Baseline Privacy (BPI+) encryption status and identify which connection parameters have passed or failed.



Link Statistics

A range of downstream and upstream link connection parameters including frequency, power, modulation, symbol rates and SNR are evaluated and displayed.



Additional DOCSIS 3.0 Modem Features

- Enhanced Security – Advanced Encryption Standard (AES)
- Pass-Through testing – modem emulation to verify high bandwidth data transfer between PC and Network

Verifying Upstream Channel Bonding

DOCSIS 3.0 provides several enhancements, most notably channel bonding giving cable operators a flexible way to increase bandwidth to customers. Upstream speeds in particular have come under a lot of pressure due to a sharp increase in user generated content such as video and photo uploads, driven by the proliferation of social and networking sites.

Checking RF Levels - Significant consideration must be given to the cumulative RF power loading that is realized with upstream channel bonding. Four upstream DOCSIS channels transmitting simultaneously can result in a large contiguous channel loading. To avoid excess power hitting the return path fiber-optic transmitter and to reduce the possibility of laser clipping, the power levels of each channel can be carefully monitored in the link measurement tab.



IPv6 Support and Network Server Verification

Once successful upranging is complete, the DOCSIS 3.0 modem registers with the Cable Modem Termination System (CMTS) and checks for an IPv6 address before looking for an IPv4 address. IP addresses from the network servers (DHCP, TFTP, TOD and DNS) are discovered and clearly displayed.



VeTest Throughput

VeTest enables download and upload throughput testing to various customer specific servers.



Ethernet

Test Interfaces

Single copper (RJ45) and optical test ports (SFP) support 100% wire speed traffic generation and reception for 10/100/1000Base-T, 1000Base-SX, 1000Base-LX or 1000Base-ZX full-duplex networks at all packet sizes.



RFC2544 Compliance Testing

Automated test suite performs throughput, latency, frame loss and back-to-back frame tests, and checks all industry recommended frame sizes (including two user defined frame sizes) up to full line rate. The test can be performed with a far end test partner in loopback mode (symmetrical traffic) or peer-to-peer mode (asymmetrical traffic). User defined test thresholds ensure accurate SLA assurance/verification while an advanced SLA mode generates background streams to closely approximate actual live traffic conditions.



Intelligent Loopbacks

Four modes are available for looping test traffic:

- Layer 1 - incoming traffic is looped back unaltered
- Layer 2 - incoming unicast traffic is looped back with MAC source/destination addresses swapped
- Layer 3 – same as layer 2 with both MAC and IP addresses swapped
- Layer 4 – same as Layer 3, with UDP/TCP ports swapped

BERT

Layer 1, 2, 3 and Layer 4 BER tests are supported. PRBS, stress or user defined test patterns simulate various conditions. Service disruption measurements including CRC error checking are performed. BER testing is possible using a physical loop at the far end (Layer 1), or using a second test unit or intelligent loopback device in Smart Loop or in Peer-to-Peer mode.

VLAN stacking (Q-in-Q) is supported for Metro and Carrier Ethernet applications. Up to three tags makes provision for carrier/service provider assigned VLANs, while retaining the VLAN of customer traffic.



Throughput Testing

Testing with multiple streams enables service providers to simulate and qualify a variety of applications and perform Ethernet QoS measurements.

• Multiple Streams Generation

Up to eight individual traffic streams can be configured with independent VLAN stacking (802.1ad Q-in-Q), VLAN ID (802.1Q), VLAN Priority (802.1p), ToS and DSCP settings.

• Delay and Jitter Measurements

Frame delay (PDV) and inter frame delay variation (IPDV) measurements based on RFC3393 recommendations are performed on test traffic during BER or throughput tests when unit is equipped with the Jitter software option.



Testing Premise

From the Customer Premise, test directly at the RF interface or through the real Cable Modem's Ethernet interface. At the CATV Headend office, connect a MPX100 or any other VeEX Ethernet test set behind the CMTS. Here the MPX functions as a Responder, with only an IP address needed to be configured on the test port. The CX380S-D3 functions as the Controller via the RF or Ethernet interface, running the RFC2544 Asymmetric test suite.

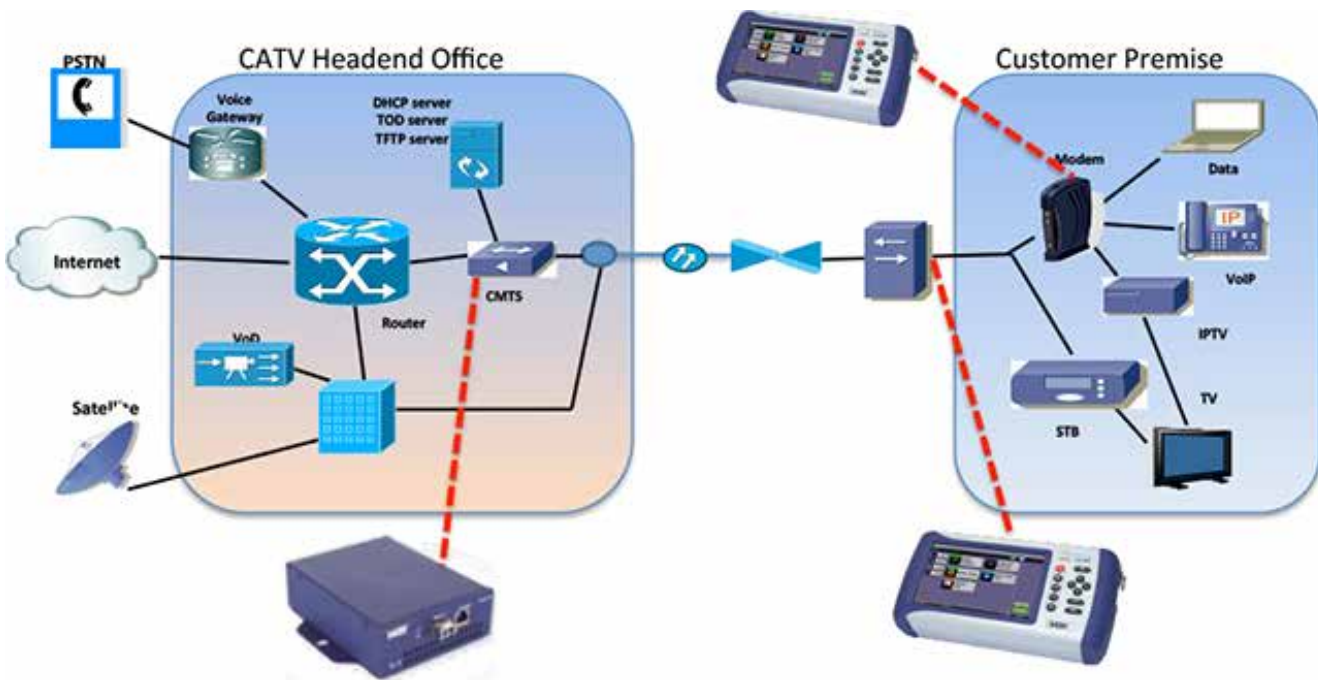

Ethernet over DOCSIS

Today's cable operator network infrastructure, which combines a 40G/10G backbone with DOCSIS 3.0 over HFC, has strongly positioned MSOs to offer business class Ethernet based services to small and medium businesses. Key service offerings include guaranteed data, hosted voice, online backup and security, and other cloud based services.

Using its built-in Ethernet test traffic engine, the CX380S-D3 can generate traffic over the DOCSIS test port to verify bi-directional, end-to-end DOCSIS throughput rates with a far-end Ethernet test device. Verification is done from the Customer Premise to the Headend CMTS.

In Ethernet over DOCSIS mode, the CX380S-D3 emulates the Cable Modem and simulates the customer's Ethernet traffic, up to maximum DOCSIS 3.0 throughput rates. This unique capability is ideal for MSOs to verify their Metro and Carrier Ethernet Service offerings.

True Gigabit Ethernet Throughput SLA

Actual Cable Modem CPE verification can be performed by connecting the CX380S-D3's Ethernet test port to the Cable Modem's Ethernet port and generate test traffic to the far-end Ethernet test device connected behind the CMTS.

Benefits

- The Asymmetric RFC2544 test suite offers an automated verification of throughput rates.
- The Throughput application enables for deeper troubleshooting and verification with differentiation of traffic flow types (Constant, Ramp and Burst) and different frame size configurations.

IP Testing

Triple Play services are IP centric, so IP test functions are no longer considered a luxury. On a daily basis, technicians verify network connections during service installation and restoration, so Ping test, Trace Route, ARP, Web browser, FTP throughput, VoIP Call emulation and IPTV measurement have become routine measurements. IP verification on the CX380S-D3 is possible over the DOCSIS Cable Modem and Gigabit Ethernet test ports. *Note: IPTV is offered on the Gigabit Ethernet interface only.*



VoIP Testing

Take advantage of the three software options offering different test methods to verify and provision your VoIP network. Testing can be performed over any of the Ethernet or DOCSIS test ports.

VoIP Check – Simulates a VoIP call to the nearest router and measures the round trip MOS score and related VoIP parameters.



VoIP Expert – Generates industry standard wave files to verify MOS and R-factor values of upstream and downstream paths and includes QoS measurements such as packet jitter, packet loss and delay. Compatible with all VeEX testers including VX1000 VoIP server software.



VoIP Call Expert – Emulates an IP phone and can place and receive calls using SIP or H.323 protocols. Comprehensive Codec support and call destination options verify voice encoding and translation provisioning. Real-time evaluation of subjective voice quality (MOS and R-factor) is made possible using the patented Telchemy® test method.



IPTV Explorer

IPTV Service Providers nowadays have to ensure the transport layer and MPEG payload are both within defined limits, because simply checking packet loss, jitter and related impairments of the Ethernet distribution network is not enough to evaluate the quality of the IPTV content carried in the upper protocol layers. The IPTV Explorer option extracts the MPEG payloads from the Ethernet streams, decodes and displays them to check transport and programming content so that QoS and QoE can all be assessed.

Note: this feature requires the Ethernet option.

Media-Stream-Based Algorithm

A proprietary and sophisticated algorithm analyzes the IP stream to assess and derive video quality and improve accuracy of quality scores.

- **Frame structure/GoP detection** – Identifies I, B and P frames in both unscrambled and encrypted video streams, to determine GoP length and the rate and distribution of packet loss in each frame
- **Per-frame quality computation** – Quality in each frame using the frame type, frame size, codec type, bandwidth and packet loss data. For P and B frames, TX300S models the loss propagated from earlier reference (I or P) frames
- **Bandwidth estimation** – the bandwidth used by certain types of video frames is analyzed to estimate the quantization level applied by the video encoder

Program Identifier (PID) Statistics

PID statistics provide critical information about the MPEG transport stream. The bandwidth and packets associated with each individual stream are listed allowing the technician to check the video, audio and data content and to check for any “illegal” PIDs.

Transmission Quality Score

QoS parameters are evaluated and presented in an intuitive manner so that technicians unfamiliar with MPEG signals are able to make accurate decisions to ensure maximum service availability.

- Audio and Video MOS scores associated with the particular video/audio codec used and transmission quality are reported
- VSTQ (Video Service Transmission Quality), is a codec-independent scoring that rates the ability of the network to reliably transport video
- ETSI TR 101 290 metrics are good indicator of transport associated errors

WiFi Spectrum Analyzer



The CX380S-D3 offers a powerful portable spectrum analyzer on a USB dongle that displays all RF activity in the WiFi bands. With dual 2.4 GHz and 5 GHz bands support, the analyzer covers all 802.11a/b/g/n networks and is the ideal tool for enterprise environments with a mix of wireless technologies.

With multiple graphical format displays it helps to visualize and locate RF signals in the spectrums as well as locate and eliminate interference sources (cordless phones, microwave ovens, Blue-tooth devices, etc.), discover and remedy competing access points.

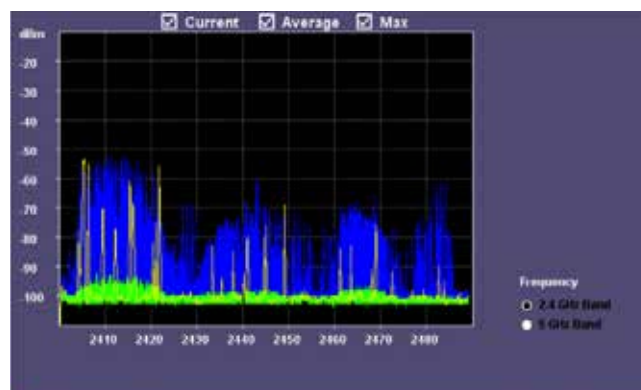

WiFi InSSIDer

The WiFi InSSIDer provides the best tools for WiFi networks discovery and performance troubleshooting. With compatible USB WiFi adapter for 802.11 a/b/g/n wireless in 2.4 GHz and 5 GHz bands the InSSIDer provides a clear picture of the environment. It helps identify poor channel placement, low signal strength and interferences in easy to understand graphs and tables.

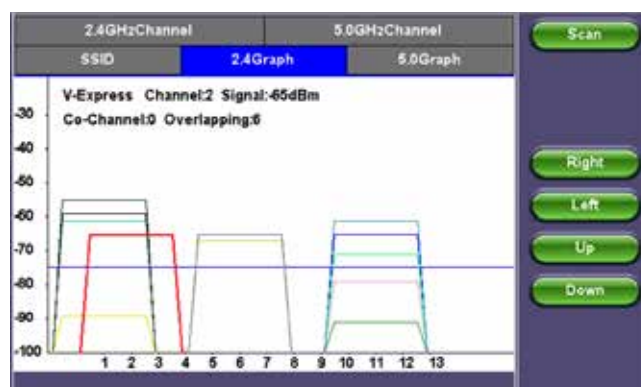

WiFi Wiz

The WiFi Wiz function with USB WiFi adapter for 802.11 a/b/g/n wireless in 2.4 GHz and 5 GHz bands makes troubleshooting WiFi connectivity issues a simple task.

Scan for available networks and view all access points detailed information along with SSID, signal strength and channel allocation. Connect to Access Points with WEP/WPA or WPA2 encryption and verify IP capabilities to ensure the wireless network is properly installed and configured. A full suite of IP testing features is supported (ping, trace, web browser, etc.).

Tools	Scan	Connect	Network
	Ping	Trace Route	ARPWiz
IP Tools	AP List		
Net Wiz	WiFi Scan Finished		
WiFi Wiz	ESSID	BSSID	Channel
Advanced	VeEX Office	00:1A:DD:A5:51:C1	1
Browser	Protected via WEP		
	VeEX-CX180	00:24:B2:C0:92:2C	1
	Protected via WPA2		
	VeEX_38	00:16:B6:51:17:4A	6
	Protected via WPA2		
	UX100	00:22:75:53:BD:7E	6
	Protected via WPA2		
Utilities	VeEX-Mktg14	9C:D3:6D:AC:9C:3E	11
Files	Protected via WPA2		

ReVeal CX300 PC Software

A software package shipped standard with each CX test set. Channel tables, location thresholds and other installation data can be created and edited on a PC for upload to the test set via USB, LAN or DOCSIS connection. Test results can be downloaded and saved to a PC, where test data management and report generation can be performed. Users are able to check and upgrade their test sets without having to return the unit to the supplier, thus reducing downtime.



VeSion R300 Productivity Server

A software application specifically designed for medium-to-large CATV operators facing the enormous challenge of coordinating hundreds of installations per day, collecting the field test results for billing/record purposes and having to maintain a large inventory of test sets in parallel. When used in conjunction with the Home Installation Process (HIP) and Signature Pad features, the application becomes a powerful tool to reduce customer call-backs and associated truck rolls, maximizing workforce efficiency and lowering operational costs.

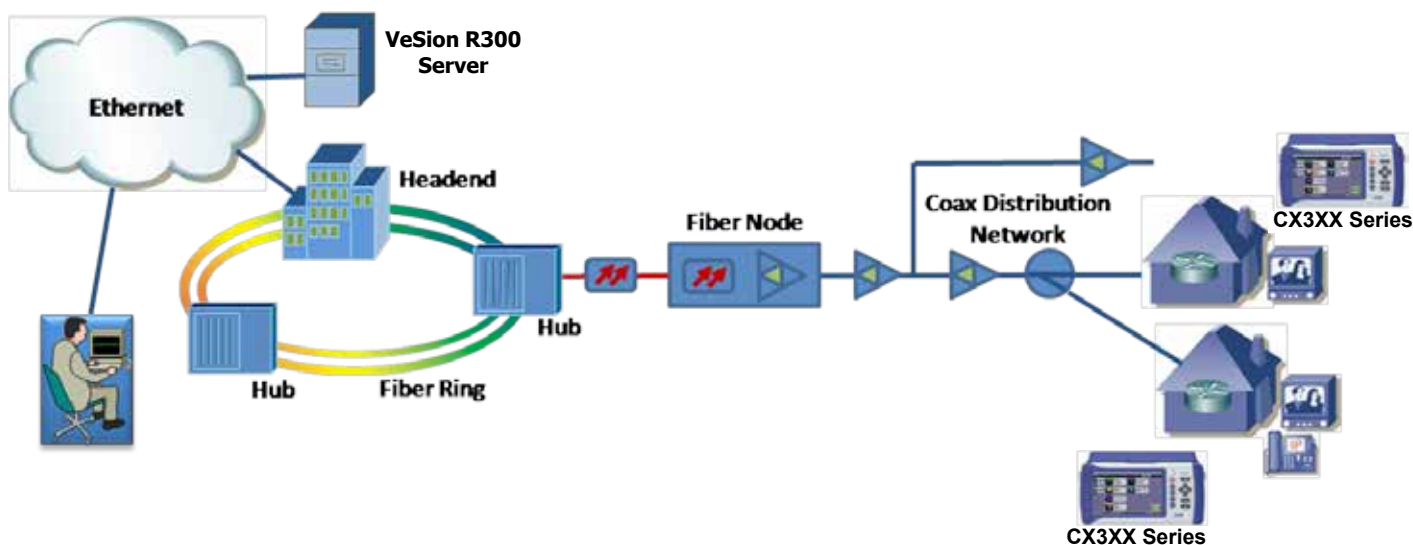

Advanced Management

Authorized test sets register with specific VeSion R300 Server/s to download new channel tables, test profiles, measurement thresholds and job cards. Test results can be uploaded via LAN interface or DOCSIS connection running over the existing RF network. Signature Pad electronically captures the customer signature which is automatically appended to the test results upon work order completion.

Benefits

- Centralized storage of test profiles, software versions and measurement thresholds
- Registered test sets are informed of new test profiles, software versions and channel tables
- Test set software versions are maintained and synchronized
- Results are collected electronically while technician is on site, thus billing transactions can be processed sooner
- Operates with Operator and Contractor owned test sets giving operational statistics for both activities
- Provides theft prevention, test set lockout, time lock and other security features

Specifications

General

Input Impedance: 75Ω
 Frequency Range: 5 MHz to 1 GHz
 Input Level Range: -50 dBmV to +60 dBmV
 Dynamic Range: 60 dB
 Display Range: 70 dB
 Vertical Scale: 1, 2, 5, 7, 10 dB
 Attenuation: 0 to 50 dB in 5 dB steps
 Frequency Reference: ± 2 ppm typical

Analog Channel Measurement

Level Range: -50 dBmV to +60 dBmV
 Level Accuracy: ± 1.5 dB
 Level Resolution: 0.1 dB
 Standards: NTSC, PAL, SECAM
 Channels: Video, Audio 1 and Audio 2, and FM V/A1, V/A2 Adjacent
 Advanced Analog Measurements: C/N, HUM, CSO/CTB

Digital Channel Measurement

Level Range: -50 dBmV to +60 dBmV
 Level Accuracy: ± 1.5 dB
 Level Resolution: 0.1 dB
 Modulation: QAM 16/64/256, Annex A/B/C
 Symbol Rate: 1 to 7 MHz programmable
 Constellation Display: QAM 16/64/256 with zoom
 Minimum QAM Locking Level: -15 dBmV
 Adaptive Equalizer Display
 MER Range: 22 dB to > 40 dB, ± 1.5 dB
 Adjacent Channel
 Pre & Post BER Range: 0 to 9×10^{-3}
 Errored and Severely Errored Seconds
 Histogram Analysis: up to 60 min per minute and per second

- MER, Pre BER, Post BER, Errored Sec, Severely Errored Sec

 Timed Stats
 Advanced Digital Measurements (software option)

- Group Delay, MaxAC, Phase Jitter, Symbol Rate Error, Frequency Error, Frequency Response, HUM, EVM, Carrier to Noise, Carrier to Ingress, QAM Ingress

Spectrum Analysis

Span: 5 MHz to 1 GHz, zero span
 Resolution Bandwidth: 1 MHz, 300 kHz, 100 kHz, 30 kHz, 10 kHz
 Video Bandwidth: 1 MHz, 100 kHz, 10 kHz, 100 Hz
 Minimum Sweep Time: 30 ms

Other Measurements

System Scan: typical 30 seconds
 Tilt: up to 8 Analog plus 8 Digital channels
 Programmable Pass/Fail Threshold: 10 sets
 Programmable Channel Table: 20 tables
 Test Point Compensation: 10 sets

Options

MPEG Transport Stream Analysis

Analyze MPEG-2 TS signal quality in a QAM channel
 Measurement parameters: Total packets, video packets, audio packets, jitter, delay, rates

MPEG Transport System Analysis Summary	
Test Result	Definition and Description
Summary Status	Summary of all alarms (packet loss, MPEG layer alarms, MDI, etc.)
Program Name	Program name for the video stream
PMT PID	Represents PID for the PMT inside the MPEG stream
#PIDs	Number of PIDs inside the MPEG stream
Video Packet Statistics	Includes video bandwidth and video packet statistics inside the program
MOS_V	Mean Opinion Score for Video perceptual quality
I/B/P Frame Statistics	Statistics for the I/B/P frames (for unscrambled video), including packet loss and bandwidth for each type of video frame
Audio Packet Statistics	Includes audio bandwidth and audio packet statistics inside the program
MOS_A	Mean Opinion Score for Audio perceptual quality
TR 101 290	Includes result parameters per TR 101 290, such as Sync loss and Sync byte, PAT, CC, PMT, PCR and CRC errors, etc.
PID Map	Detail description for each PID inside the MPEG TS

Upstream Signal Generator

CW Generator

Frequency Range: 5 MHz to 65 MHz
 Level Range: 0 to +58 dBmV
 Level Accuracy: ± 1 dB
 Level Adjustable Step: ± 1 dB
 Frequency Adjustable Step: 125 kHz/step
 Frequency Accuracy: 5 ppm
 Settling Time: less than 2 ms

QAM Generator

Modulation Type: QAM 16/64/128/256 Annex A/B
 Symbol Rate: 1.28 MHz, 2.56 MHz, 5.12 MHz, programmable 1 to 7 MHz
 Frequency Range: 5 to 65 MHz
 Level Range: 0 to +58 dBmV
 Level Accuracy: ± 1 dB
 Level Adjustable Step: ± 1 dB
 Frequency Adjustable Step: 250 kHz/step
 Frequency Accuracy: 5 ppm
 Settling Time: less than 5 ms

Return Path QAM Analysis

Modulation: QPSK, QAM 16/64/128/256
 Symbol Rate: 1.28 MHz, 2.56 MHz, 5.12 MHz, programmable
 Minimum QAM Locking Level: -15 dBmV typical
 Constellation Diagram
 MER Range: 22 dB to > 40 dB, ± 1 dB
 Adaptive Equalizer Display
 Pre & Post BER Range: 9×10^{-3} to 9×10^{-9}
 Errored and Severely Errored Seconds

Cable Modem DOCSIS/EuroDOCSIS 3.0/2.0/1.1 compliant

Downstream/Receiver

- Demodulation: QAM 64/256/1024
- Frequency Range
 - DOCSIS: 88 MHz to 1002 MHz
 - EuroDOCSIS: 108 MHz to 1002 MHz
- Maximum Speed: 320 Mbps (EuroDOCSIS with 8 D/S bonding)
- Channel Bonding: Up to 8 channels (contiguous or non-contiguous)
- Bandwidth
 - DOCSIS: 6 MHz
 - EuroDOCSIS: 8 MHz
- Input Power Level: -15 dBmV to +15 dBmV

Upstream/Transmitter

- Modulation: QPSK, QAM 8/16/32/64/128
- Frequency Range
 - DOCSIS: 5 to 42 MHz
 - EuroDOCSIS: 5 to 65 MHz
- Maximum Speed: 160 Mbps (EuroDOCSIS with 4 U/S bonding)
- Channel Bonding: Up to 4 channels
- Output Signal Level
 - QAM 32/64: +8 to +54 dBmV
 - QPSK: +8 to +58 dBmV
 - S-CDMA: +8 to +53 dBmV

General

- IPv4 and IPv6 support
- DHCP client obtains IP and DNS server address from DHCP server automatically
- Time of Day (ToD) support for local & MSO time synchronization
- TFTP Client support for cable modem configuration file download
- Security: BPI+ and AES support
- Pass-Through testing (1000BaseT port): Verify high bandwidth data transfer between PC and Network

Ethernet

Interfaces

Single 10/100/1000Base-T Ports: RJ45 connector, IEEE 802.3 compliant

Single 1000Base-X SFP Ports: SFP, LC connector

1000Base-SX

Wavelength: 850 nm
 TX level: -9 to -3 dBm
 RX level sensitivity: -20 dBm
 Max reach: 550m
 TX bit rate: 1.25 Gbps
 RX bit rate: 1.25 Gbps
 Jitter Compliance: According to IEEE 802.3 recommendations
 Ethernet Classification: According to IEEE 802.3 recommendations
 Eye Safety: Class 1

1000Base-LX

Wavelength: 1310 nm
 TX level: -9.5 to -3 dBm
 RX sensitivity: -22 dBm
 Max reach: 10 km
 TX bit rate: 1.25 Gbps
 RX bit rate: 1.25 Gbps
 Jitter Compliance: According to IEEE 802.3 recommendations
 Ethernet Classification: According to IEEE 802.3 recommendations
 Eye Safety: Class 1

1000Base-ZX

Wavelength: 1550 nm
 TX level: 0 to +5 dBm
 RX sensitivity: -22 dBm
 Max reach: 80 km
 TX bit rate: 1.25 Gbps
 RX bit rate: 1.25 Gbps
 Eye Safety: Class 1

Ethernet Features

Auto Negotiation
 Full and Half Duplex
 Flow Control

Modes of Operation

Terminate
 Monitor
 Pass through
 Loopback

Traffic Generation

IEEE 802.3 and Ethernet II (DIX) frames
 Configurable MAC, Ethernet Type, VLAN, MPLS, IP, UDP header fields
 Constant, Ramp, and Burst traffic profiles with configurable bandwidth % utilization
 Jumbo Frame Support (10,000 bytes)
 Fixed, multiple and random frame size generation
 Traffic prioritization via VLAN priority field, MPLS CoS field and the IP TOS/DSCP fields
 Up to 3 VLAN and MPLS tags can be added to each user configured traffic stream

RFC2544 Compliance Testing

Automated tests with configurable threshold values and maximum transmit bandwidth settings
 Throughput, Latency, Frame Loss and Back-to-Back (burst) tests
 Frame sizes: 64, 128, 256, 512, 1024, 1280 and 1518 bytes including 2 user configurable frames

Bit Error Rate Testing

Patterns: PRBS 2³¹-1, PRBS 2²³-1, PRBS 2²⁰-1, PRBS 2¹⁵-1, PRBS 2¹¹-1, CRPAT (Layer 1 only), CSPAT (Layer 1 only), CRTPAT (Layer 1 only), Normal and inverted patterns
 Error Injection: Bit, CRC, Symbol, IP Checksum
 One configurable stream with one fixed frame size

Traffic Filters

Up to eight traffic filters can be configured with MAC, VLAN and IP fields for Monitor and Loopback modes

Multiple Streams Throughput Testing

Up to eight independent traffic streams with configurable MAC, VLAN, MPLS and IP fields including traffic prioritization via the VLAN tag priority field and the IP header TOS/DSCP field
% of bandwidth allocation is configurable for each stream
Different traffic profiles (constant, ramp or bursty) may be configured for different streams
Different frame sizes are user configurable per stream

Smart Loop

Layer 1: loops back all incoming traffic
Layer 2: all incoming unicast traffic is looped back with MAC source and destination addresses swapped
Layer 3: all incoming unicast traffic is looped back with MAC and IP source and destination addresses swapped
Layer 4: all incoming unicast traffic is looped back with MAC, IP and UDP/TCP ports swapped

Key Measurements

Error Measurements: Bit, CRC, symbol, IP checksum, jabber frames, runt frames, collisions, late collisions

Alarm Detection: LOS, pattern loss, service disruption

Frame/Packet Statistics: Multicast, broadcast, unicast, pause frames, frame size distribution, bandwidth utilization, frame rate, line rate, data rate, frame loss, frame delay variation

IPTV

Requires Ethernet option

Mode: Monitor

Stream configuration: Unicast, multicast, IP address, Port number

Codecs: MPEG2, MPEG4 (Part2) and MPEG4 Part10 (H.264)

Probe function with streams auto-detection

IPTV image viewer for channel identification (does not decode encrypted streams)

Stream Analysis

- PIDs count
- PID MAP
- Transport Error count
- Data rates: Video, Audio, Data (Bandwidth and Packet Counts)

Video Analysis

- MOS_Video, Video Service Transmission Quality (VSTQ), Estimated Peak Signal to Noise Ratio (EPSNR ATIS)
- I/B/P Frame statistics (Bandwidth, # Frames Received, Lost, Impaired)

Audio Analysis

- MOS_Audio

TR 101 290 Metrics

- Sync loss, sync byte error, PAT/PAT2 error, Continuity error, PMT/PMT2 error, PID error, transport error, CRC error, PCR discontinuity, PCR accuracy error

IP Testing

Ping, Trace Route, ARP, FTP/Web tests, Web-browser. These tests are done via the chassis 10/100Base-T port, Cable Modem emulation or USB WiFi adaptor. CX380S-D3-D3 also supports VeTest, a throughput test, in Cable Modem emulation mode.

VoIP Testing

VoIP Check

- Simulates VoIP call to the nearest router/CMTS
- Round Trip MOS score

VoIP Expert

- MOS and R-factor measurement
- Packet Statistics: packet loss, jitter, delay

VoIP Call Expert

- VoIP call setup with VoIP USB adaptor
- Supports SIP and H.323 protocols
- Codec: G.711U, G.711A, Optional G.723, G.729

WiFi Wiz

Requires compatible USB WiFi adapter for a/b/g/n networks in 2.4 GHz and 5 GHz bands

Access Points scan with signal level and link quality measurement

WEP/WPA1/WPA2 encryption

IP Connectivity test (Ping, trace route, ARPWiz, Web browser)

Provides Wi-Fi LAN access to the test set (e.g. VeExpress, R-Server, Remote Control, ReVeal)

Requires Wi-Fi USB transceiver

WiFi InSSIDER

Requires compatible USB WiFi adapter for a/b/g/n networks in 2.4 GHz and 5 GHz bands

Network scan results in Graphical or table format

Lists: Network names, BSSID, encryption type, channel allocation, signal strength, co-channels and overlapping channels

Requires Wi-Fi USB transceiver

WiFi Spectrum Analyzer

Supports 802.11 a/b/g/n

Frequency Range: 2.400 to 2.495 GHz and 5.150 to 5.850 GHz

Amplitude Range: -100 to -6.5 dBm

Antenna: RP-SMA

Planar, topographic, spectral view

Requires Wi-Fi Spectrum Analyzer USB dongle

General Specifications

Size	290 x 140 x 66 mm (W x H x D) 11.40 x 5.50 x 2.60 in
Weight	Less than 2.5 kg (less than 5.5 lb)
Battery	Lilon smart battery 5200 mAh 10.8VDC
Battery Operating Time	> 4 hours continuous measurement > 9 hours idle
AC Adaptor	Input: 100-240 VAC, 50-60 Hz Output: 15 VDC, 6A
Operating Temperature	0°C to 45°C (32°F to 122°F)
Storage Temperature	-20°C to 70°C (-4°F to 158°F)
Humidity	5% to 95% non-condensing
Display	7" full color touch-screen display
Ruggedness	Survives 1m (3 ft) drop to concrete
Interfaces	USB 2.0, RJ45, 10/100-T Ethernet, Bluetooth 2.0 (optional)
Languages	Multiple languages support



VeEX Inc.
2827 Lakeview Court
Fremont, CA 94538 USA
Tel: +1.510.651.0500
Fax: +1.510.651.0505
www.veexinc.com
customercare@veexinc.com

© 2014 VeEX Inc. All rights reserved.
VeEX is a registered trademark of VeEX Inc. The information contained in this document is accurate. However, we reserve the right to change any contents at any time without notice. We accept no responsibility for any errors or omissions. In case of discrepancy, the web version takes precedence over any printed literature.
D05-00-074P B00 2014/05